

Konica

MEDICAL FILM PROCESSOR

Model SRX-101A

SERVICE MANUAL

CODE NO. 1051/1052

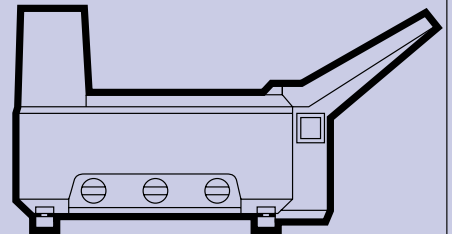

KONICA CORPORATION

No. 26-2, Nishishinjuku 1-chome, Shinjuku-ku, Tokyo 163-0512, Japan



SERVICE MANUAL

SRX-101A Medical Film Processor

Code No. 1051/1052

Contents

■ Precautions.....	1
■ Tools and Instrument.....	1
■ Caution Labels	2
1. Specifications.....	4
2. Dimensions.....	5
3. Name of Parts.....	6
4. Time Chart	20
5. Troubleshooting.....	21
6. CPU Board DIP Switches	46
7. Checking Circuit Boards Sensors and Electrical Loads.....	47
8. Developer Temperature Correction.....	51
9. Electrical Components Diagram.....	52
10. Wiring Diagram of Main Unit.....	53
11. Circuit Board Diagram.....	55
12. Pre-Installation Instructions	63
13. Installation Instructions and Precautions	70
14. Changing Processing Conditions	82
15. SRX-101A Customer Presentation Guide.....	83
16. SRX-101A Light Shield Installation Manual.....	89
17. Installation Procedure	91

■ PRECAUTIONS

Before shipment from the factory, the procedure has already been inspected according to local safety regulations.

However, the following precautions must be taken when servicing this equipment.

- (1) Before servicing, disconnect the automatic processor's power plug from its AC outlet.
If it is absolutely necessary to repair the processor while the power is on, be sure to take precautions to avoid electrical shock and keep your fingers away from rollers, gears and other moving parts.
- (2) Use only the types of fuses specified in this manual.
- (3) Use only the replacement parts specified in this manual.
- (4) When unplugging connectors, disconnect them at the socket. Do not pull on the wire bundle.
- (5) When carrying or shipping circuit boards, place them in static-proof bags, or containers made of conductive material to prevent damage from static electricity.
- (6) Do not touch the wiring patterns, connector contacts or solder on the circuit boards.
- (7) Take care to prevent washers, bolts or other metal objects from falling into the machine and causing short circuit or damage to gears. etc.
- (8) Remodeling of processor components or systems which is not described in this operation manual is forbidden.
- (9) After repairs, make sure all parts and wiring have been correctly replaced and reconnected.

■ TOOLS AND INSTRUMENT

In addition to your standard service-use tool kit, the following special tools and equipment will be necessary.

- (1) Push-pull Gauge (Max. 500g)

CAUTION LABEL

■ CAUTION LABELS

1. EXPLANATION OF CAUTION LABELS

- Caution labels imply the degree of the risk which may arise from incorrect use of this product.
- There are 3 degrees of caution labels, and each is used depending on the level of risk and damage caused by incorrect use and mishandling.

DANGER : If failed to avoid the risk, this implies the imminent danger level which may lead to serious injury including a loss of life.

WARNING : If failed to avoid the risk, this implies the danger level which may lead to serious injury including a loss of life.

CAUTION : If failed to avoid the risk, this implies the danger level which may lead to moderate damage or light injury. Also it is used when a physical damage alone is expected.

		Risk of the damage	
		High	Low
Bodily injury (and damage to property)	Loss of life or serious injury (Damage is serious)	DANGER	WARNING
	Moderate damage or light injury (Damage is light)	WARNING or CAUTION	CAUTION
Damage to property only		CAUTION	

Should this manual become not readable due to any reason, replace it with a new one which is available at charged basis.

2. WARNING LABELS AND THEIR LOCATIONS

① UL

注意 正しくラックをセットした後、母液供給を行なってください。万一、液が入っている場合には、液面が「指示マーク」の間にあることを確認してください。セット時には、ラックをゆっくりと降ろしてください。

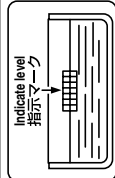

CAUTION

Make sure that the initial chemicals are filled after the completion of rack setting.

If chemicals have been filled.

- ① Make sure that chemicals are not exceeding the indicate level.
- ② Rack setting should be done with care so it does not cause a spill.

To prevent cross-contamination tilt rack to rear of processor when removing.

TÜV

CAUTION

Make sure that the initial chemicals are filled after the completion of rack setting.

If chemicals have been filled.

- ① Make sure that chemicals are not exceeding the indicate level.
- ② Rack setting should be done with care so it does not cause a spill.

To prevent cross-contamination tilt rack to rear of processor when removing.

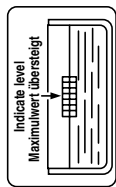

VORSICHT

Lösen Sie des automatische Befüllen der Tanks erst aus, wenn die Rollensätze korrekt eingesetzt worden sind.

Einsetzen der Rollensätze in gefüllte Tanks:

- ① Stellen Sie sicher, daß der Füllstand in den Tanks nicht den angezeigten .
- ② Die Rollensätze langsam einsetzen, ohne diese fallen zu lassen.

*Um ungewollte Chemikalienvermischungen zwischen den Bädern zu vermeiden, neigen Sie einen Rollensatz nach hinten in Richtung Tank, wenn Sie ihn aus der Maschine entnehmen wollen.

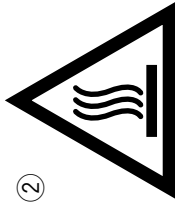

②

①

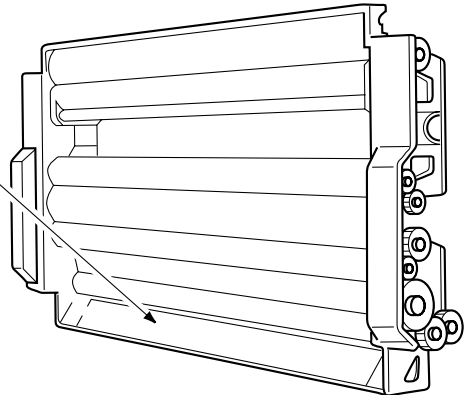
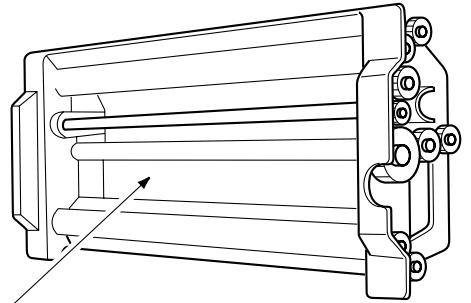
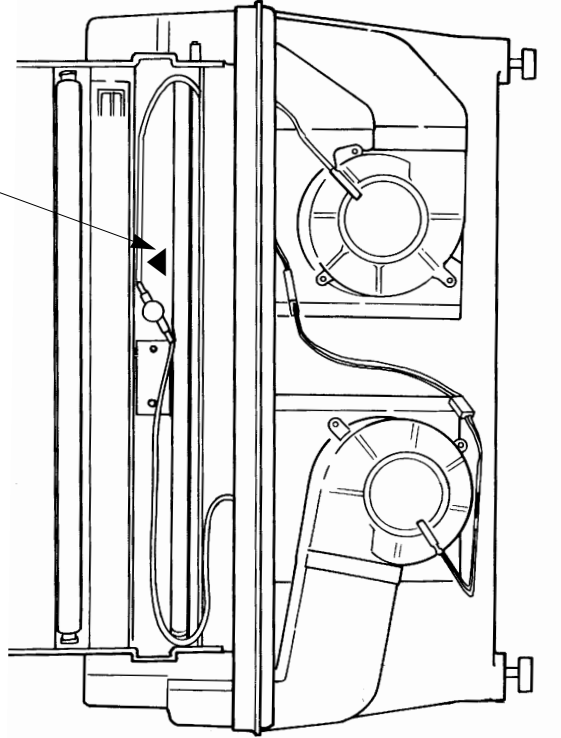

SPECIFICATIONS

1. Specifications

Model name	: SRX-101A												
Film transport method	: Continuous roller transport.												
Film type and sizes	: Sheet film, 10 x 10 cm~ 35 x 43 cm(14 x 17 inch) sizes.												
Processing capacity	: <table border="1" style="display: inline-table; border-collapse: collapse; text-align: center;"> <thead> <tr> <th style="text-align: left;">Cycle \ Size</th> <th>24 x 30 cm or 10 x 12 inch</th> <th>35 x 43 cm(14 x 17 inch)</th> </tr> </thead> <tbody> <tr> <td>90sec.</td> <td>75</td> <td>60</td> </tr> <tr> <td>120sec.</td> <td>70</td> <td>55</td> </tr> <tr> <td>180sec.</td> <td>55</td> <td>40</td> </tr> </tbody> </table> (sheets/hr)	Cycle \ Size	24 x 30 cm or 10 x 12 inch	35 x 43 cm(14 x 17 inch)	90sec.	75	60	120sec.	70	55	180sec.	55	40
Cycle \ Size	24 x 30 cm or 10 x 12 inch	35 x 43 cm(14 x 17 inch)											
90sec.	75	60											
120sec.	70	55											
180sec.	55	40											
Process cycle switching	: Available by a service engineer.												
Processing solution volumes	: DEV tank : 3.9 liters(1.03 gallons) FIX tank : 1.8 liters(0.47 gallons) WASH tank : 1.4 liters(0.37 gallons)												
Temperature control	: Processing solution temperature; Controlled by the temperature control tank, with the thermistor monitoring, and with the heater heating. Drying temperature; Controlled automatically according to a fixed temperature setting.												
Replenishing system	: Replenishing volume for the film sheet is calculated exchanging with 24 x 30 cm or 10 x12 inch film												
Circulation system	: Continuous pumping of developer and fixer solutions.												
Wash water	: Ordinary tap water 5 ~ 30°C (41 ~ 86°F) Water pressure 29.4 ~ 784 kPa(0.3 ~ 8kgf/cm ² , 98 ~ 112psi)												
Water supply	: 0.8 liters(0.22 gallons)/min.												
Standby functions	: 10min./30min./Continuous operation. (Selectable by a service engineer)												
Power source	: AC 115/120V, single phase, 12A, 60 Hz. AC 200/230/240V, single phase, 6A, 50Hz.												
Dimensions(W x D x H)	: 610 x 680(900 incl. feed table) x 453 mm 24.0 x 26.8(35.4 incl. feed table) x 17.8 inch.												
Weight	: CE 40kg (47kg with processing tank full) UL 37kg (44kg with processing tank full) 81 lb (97 lb with processing tank full)												
Certification	: Conforms to UL, FDA, TÜV												
Applied standard	: FCC/CE												
Heat generation	: Approx.3135kJ/hr max.												
Noise level	: Approx.55dB(A) max.												
Operating condition	: 15 ~ 30°C (59 ~ 86°F), 30 ~ 75%RH(no condensation)												
Storage and transport condition	: -20 ~ 60°C (-4 ~ 140°F), 20 ~ 95%RH(no condensation)												
Accessories	: Measuring cup, Funnel, Installation parts kit, Replacement parts kit, Replenisher tanks, and Operation manual.												
Optional equipment	: Light shield panel, Stand, Splash guard, DEV Temp. Control kit.(CE only)												
Remarks for CE Version	: This equipment is the CE marking product conformable to the directive MDD93/42/EEC and the harmonized standard EN60601-1, EN60601-1-2 .												

*The above specifications are subject to change without prior notice.

2. Dimensions

2-1. Main Unit and Support

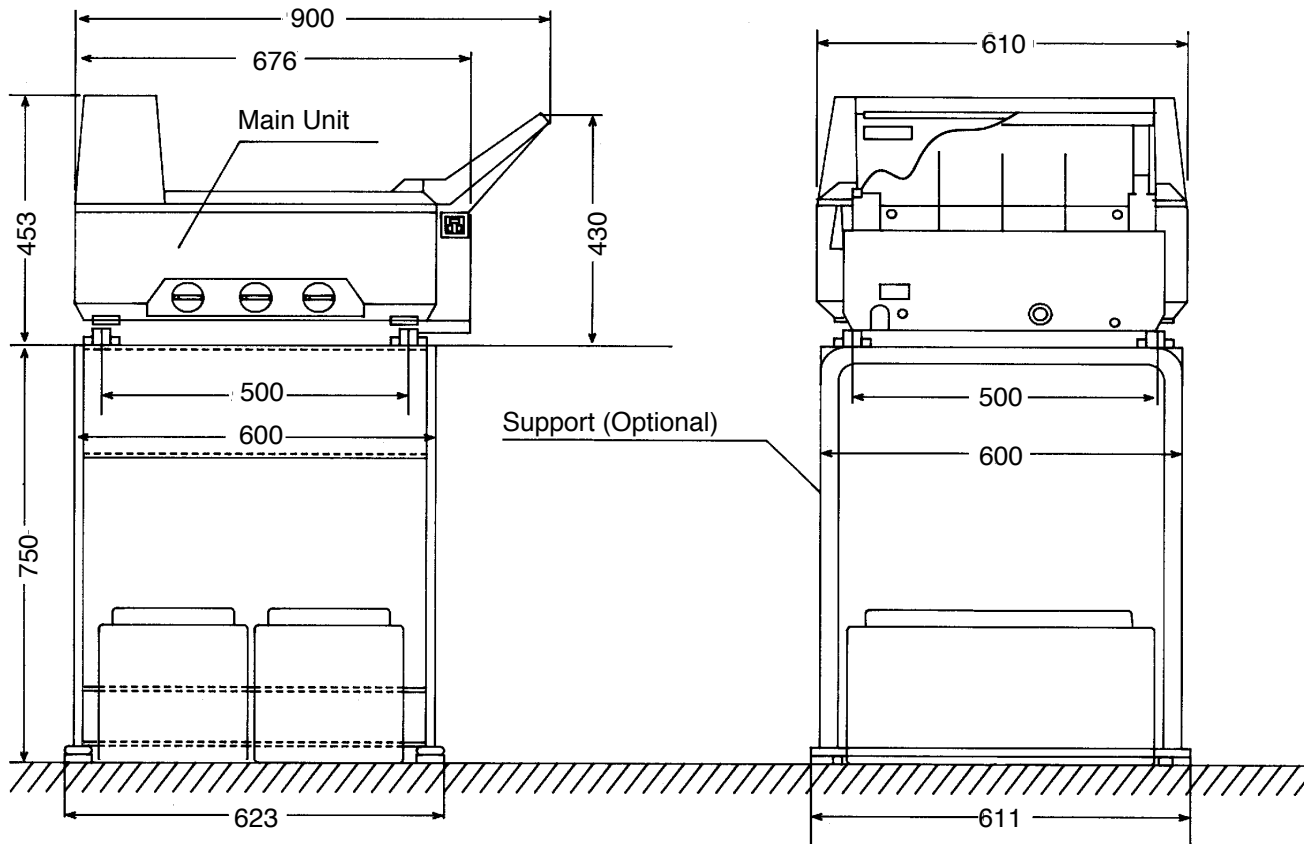

2-2. 25 Liter Replenisher Tank (Standard Equipment)

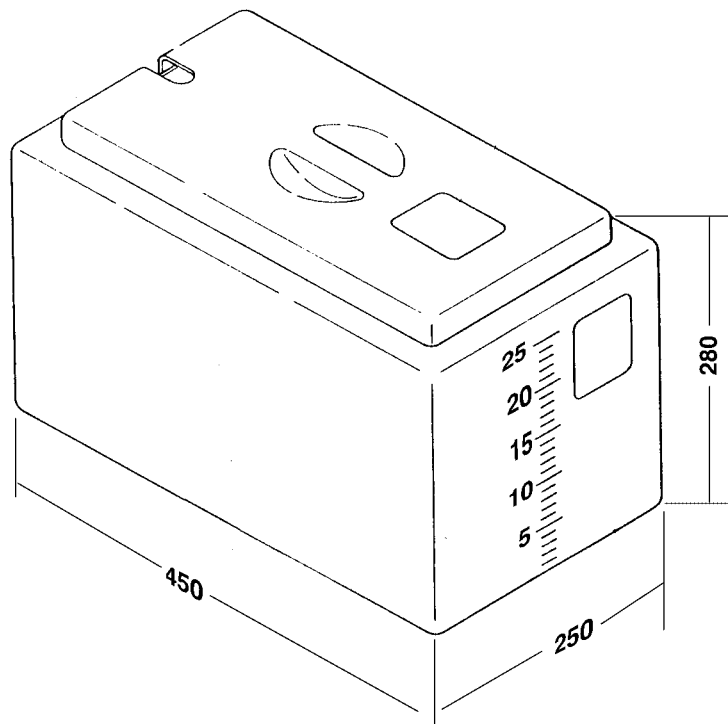

NAME OF PARTS

3. Name of Parts

3-1. Main Unit (Front View)

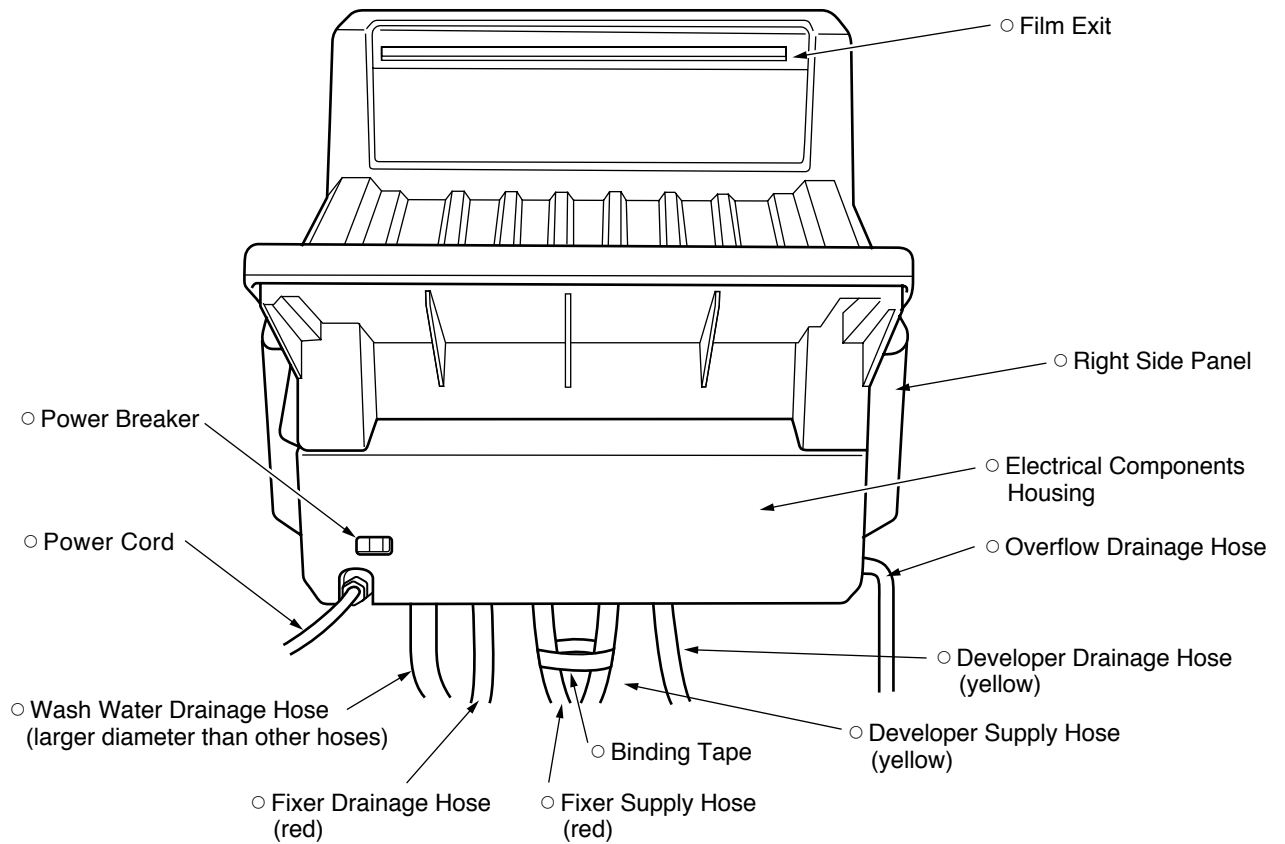

3-2. Main Unit (Left Side View)

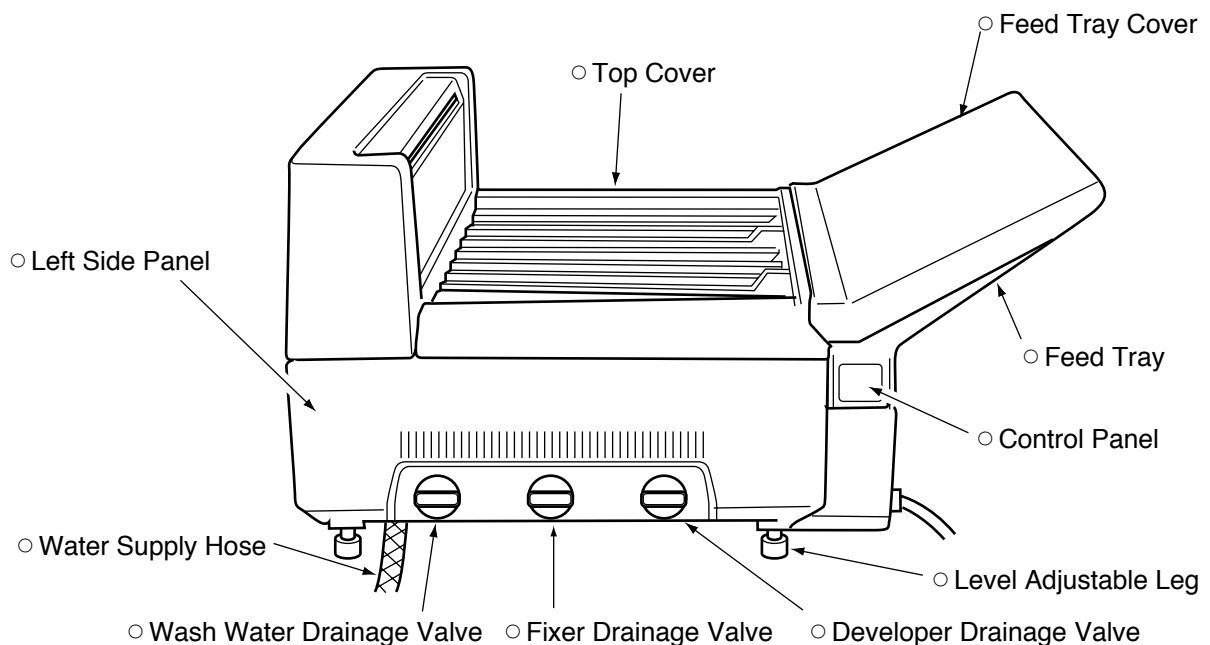

3-3. Main Unit (Rear View)

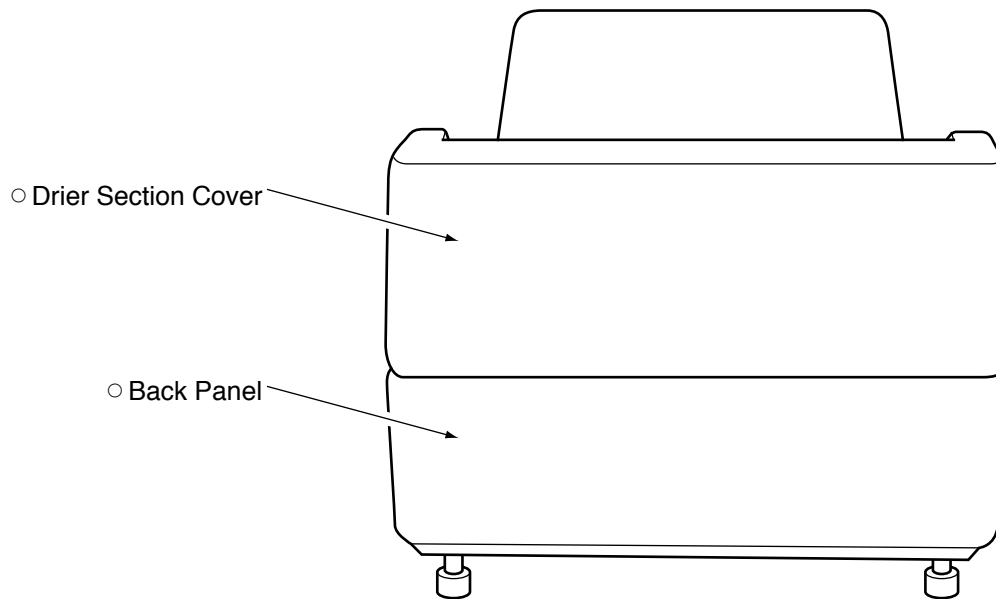

○ Drier Section Cover

○ Back Panel



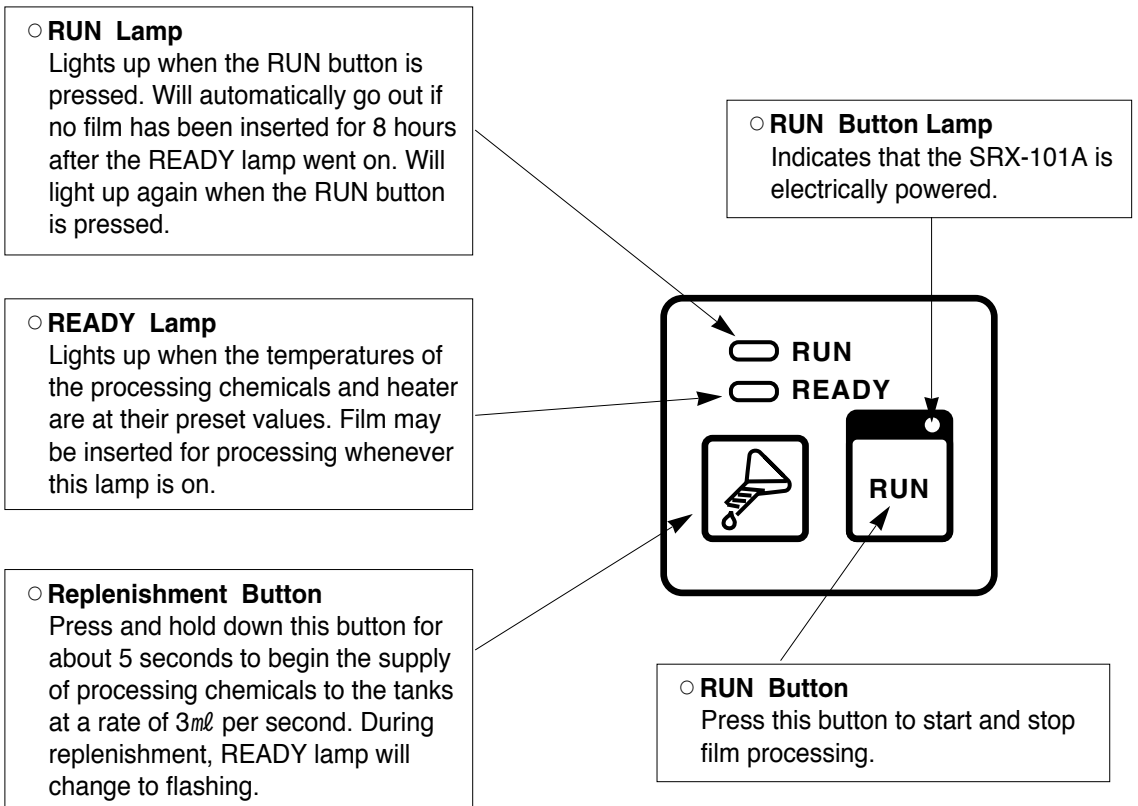











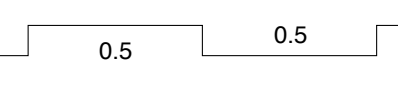

3-4. Control Panel

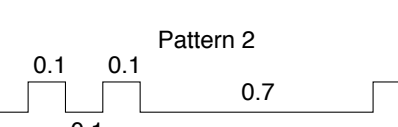

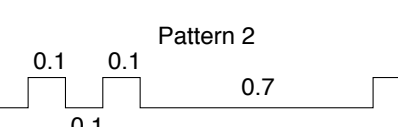

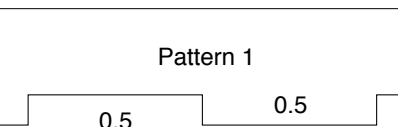
NAME OF PARTS

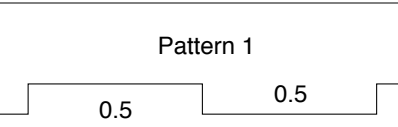
RUN and READY Lamps ON-OFF Patterns

Different ON-OFF patterns shown by the RUN and READY lamps on the control panel indicate different operating conditions. The following is a listing of all the possibilities and the conditions they indicate.

ON-OFF Pattern		Operating Condition	Note ⁽¹⁾
RUN	OFF 	All operations shut down	
READY	OFF 		
RUN	ON 	Normal operation (Operating temperature LOW)	
READY	ON 		
RUN	ON 	Normal operation (Operating temperature OK)	
READY	OFF 		
RUN	OFF Flashing(Pattern 1) 	Preparing for supplying chemical solutions (Repl. switch ON for 5 sec.)	 Pattern 1
READY	ON 		
RUN	OFF Flashing(Pattern 2) 	Supplying chemical solutions	 Pattern 2
READY	ON 		
RUN	ON Flashing(Pattern 2) 	Manual replenishment	 Pattern 2
READY	ON 		
RUN	Flashing(Pattern 1) 	Drive motor error	 Pattern 1
READY	OFF 		
RUN	Flashing(Pattern 1) 	Temperature error	 Pattern 1
READY	ON 		

When errors occur, be sure to turn off the power breaker.(S1)
(Refer to 5. TROUBLESHOOTING page 21.)

(1)  : ON time(in seconds)
 : OFF time(in seconds)

3-5. Main Unit (Top View)

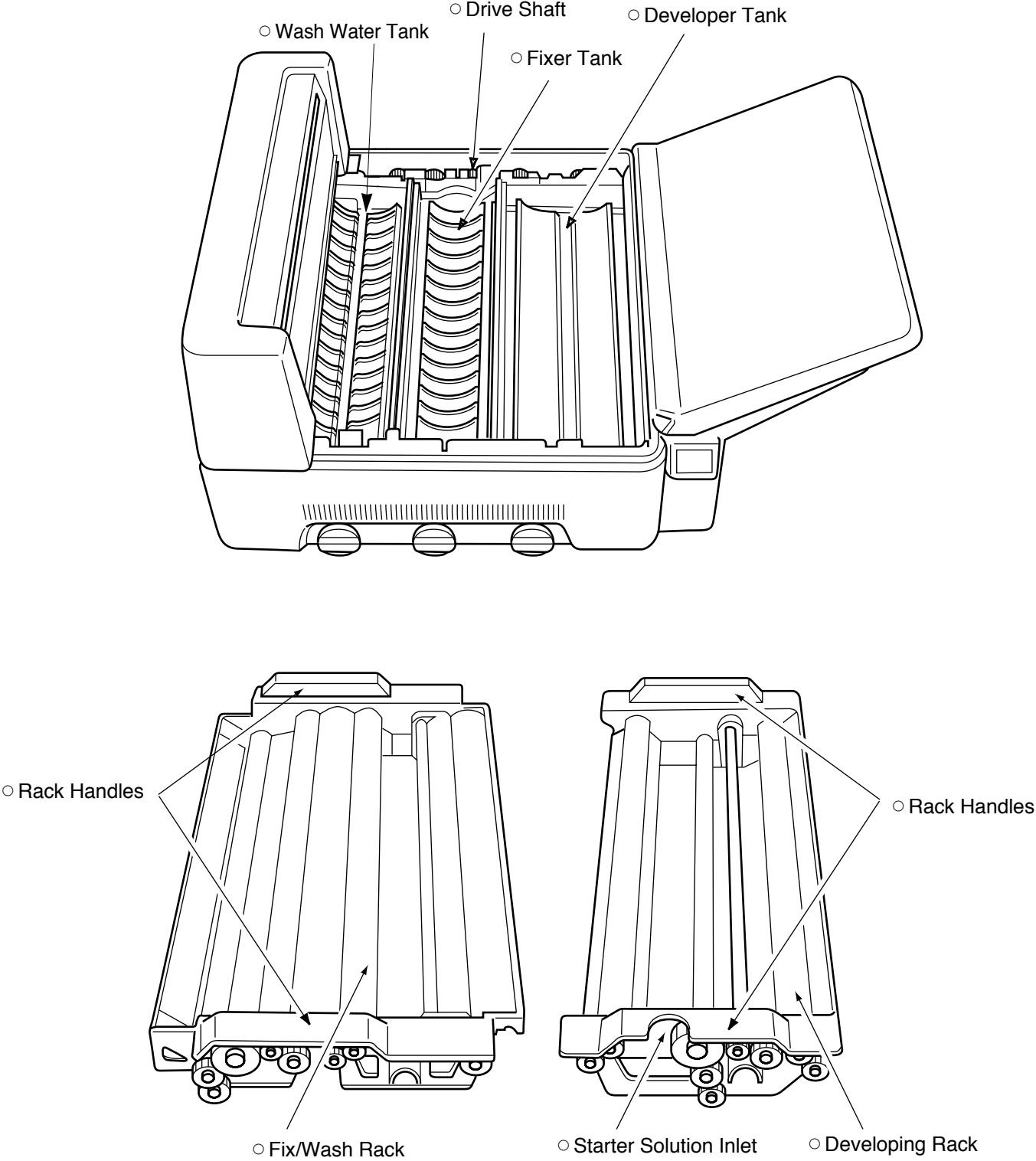

NAME OF PARTS

3-6. Drying Unit

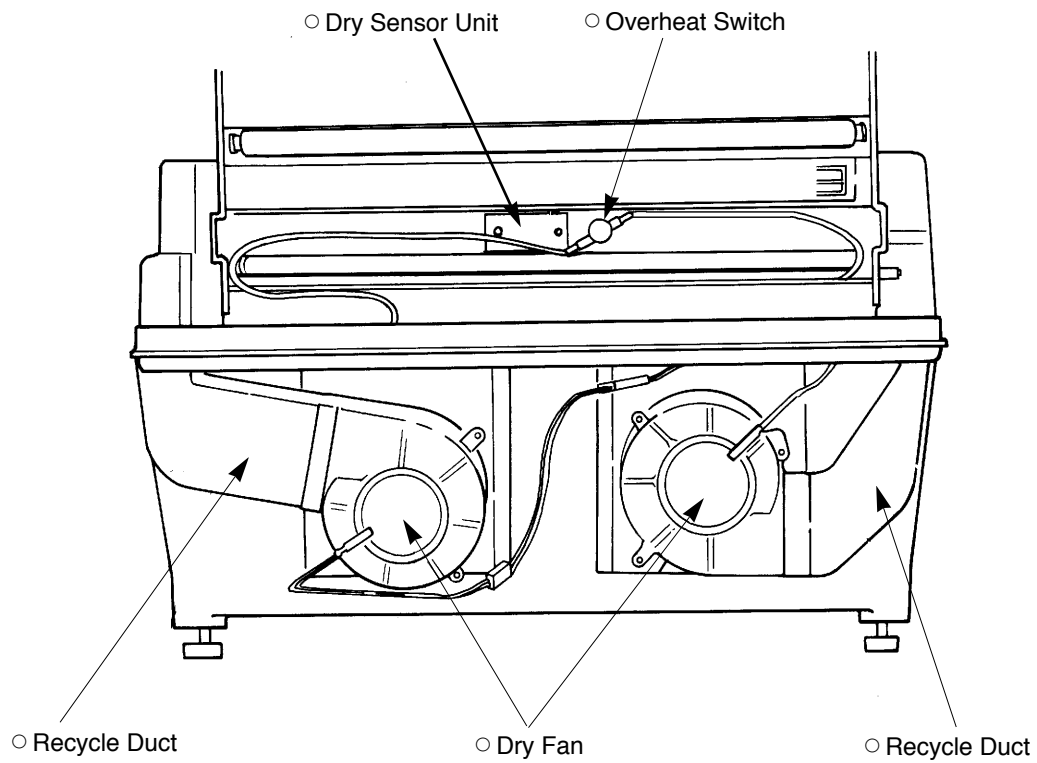
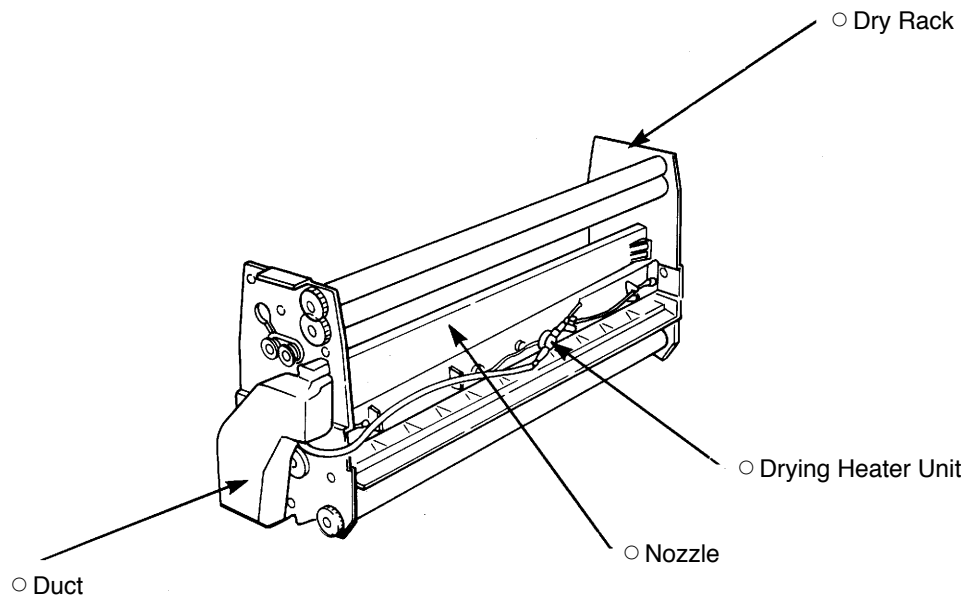

3-7. Film Transport

1) Rollers

(1) Components Diagram

Springs Type	Parts No.
L=74	1361013050
L=80	103014027A

Worm Gear	Parts No.
Right	1050-13003A
Left	1050-13004A

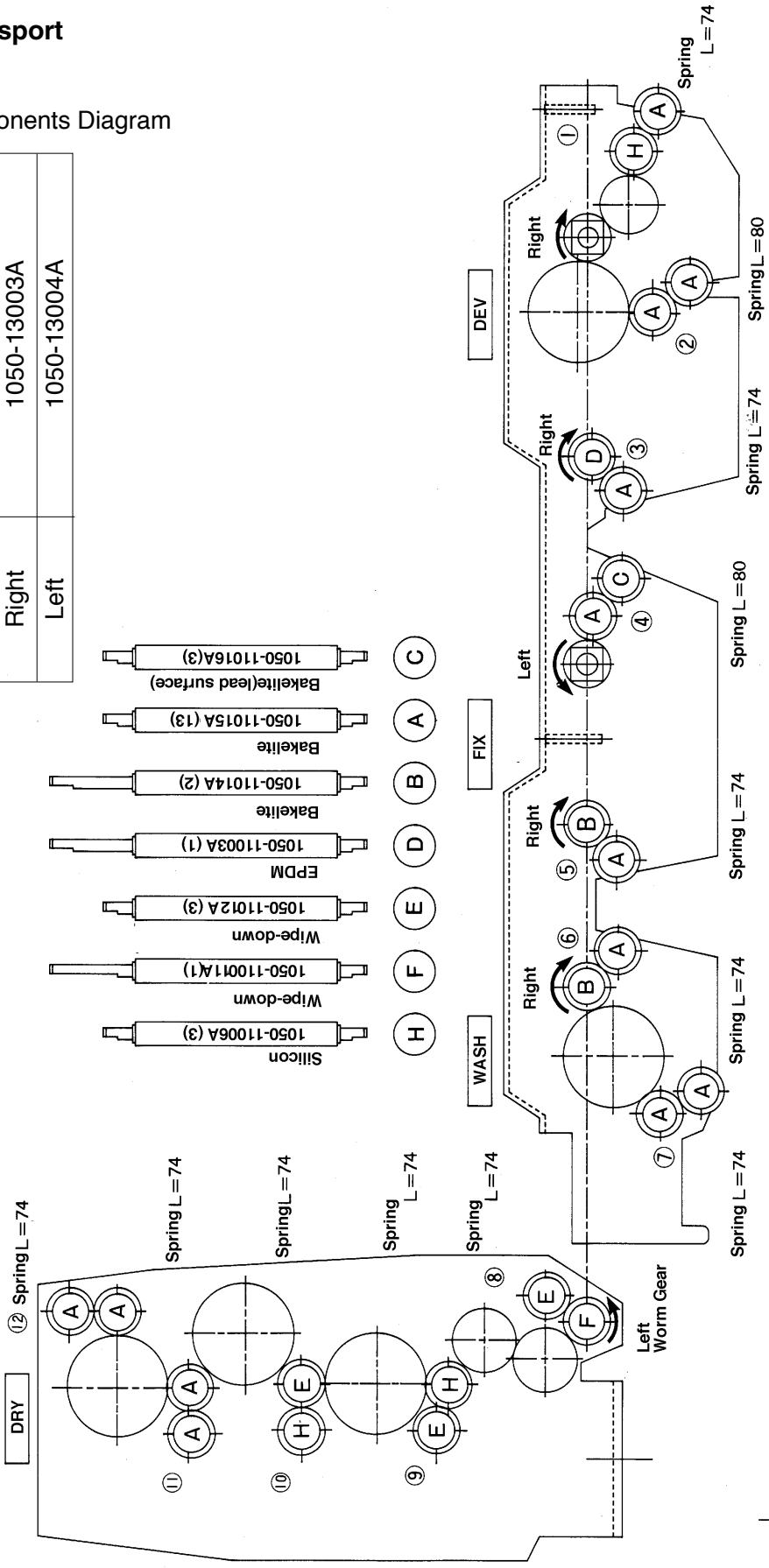

* Springs are in the opposite side, too

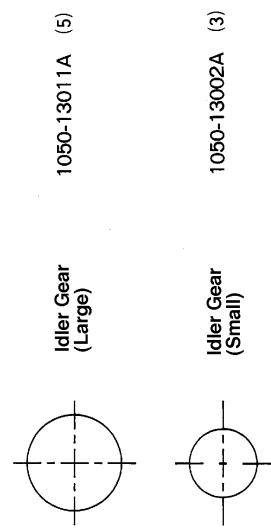

NAME OF PARTS

(2) Roller Component Listing

Processing Unit	Roller No.	Upper roller material	Lower roller material	Spring length	Spring pressure in grams
DEV	①	Silicon (H)	Bakelite (A)	74mm	410~480
	②	Bakelite (A)	Bakelite (A)	80mm	110~170
	③	EPDM (D)	Bakelite (A)	74mm	410~520
FIX	④	Bakelite (A)	Bakelite(lead surface) (C)	80mm	180~270
	⑤	Bakelite (B)	Bakelite (A)	74mm	490~530
WASH	⑥	Bakelite (B)	Bakelite (B)	74mm	450~530
	⑦	Bakelite (A)	Bakelite (A)	74mm	330~530
DRY	⑧	Wipe-down (E)	Wipe-down (F)	74mm	610~860
	⑨	Silicon (H)	Wipe-down (E)	74mm	590~720
	⑩	Wipe-down (E)	Silicon (H)	74mm	470~620
	⑪	Bakelite (A)	Bakelite (A)	74mm	410~520
	⑫	Bakelite (A)	Bakelite (A)	74mm	460~560

NOTE :

In the processing tanks, the "upper" rollers are vertically higher rollers in the solution. In the drying unit, the "upper" rollers are the rollers closer to the feed tray side of the main unit. the rollers on the other side are the "lower" rollers.

(3) Capability

The SRX-101A is capable of processing film ranging in size from 10 x 10 cm to 35 x 43cm (14x17 inch). The feed tray has an insertion slot that will feed film up to 17" in width.

2) Drive Mechanism

(1) Components Diagram

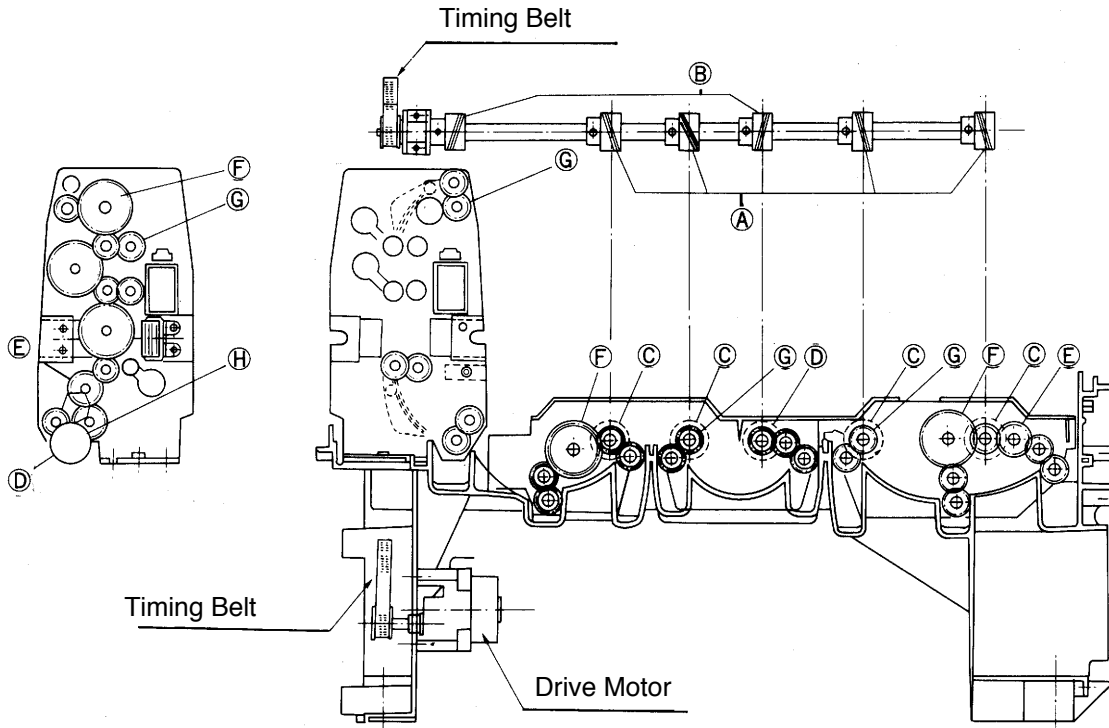

Gear Type	Symbol	Parts No.	Name	Module	No. of Teeth	Note
Worm Gear	(A)	13003A	Worm Gear (Right)	1.5	3	CW
	(B)	13004A	Worm Gear (Left)	1.5	3	CCW
Worm Gear	(C)	13007B	Worm Wheel (Right)	1.5	18	CW
	(D)	13008B	Worm Wheel (Left)	1.5	18	CCW
Idler Gear	(E)	13002A	Idler Gear (small)	1.5	16	
	(F)	13011A	Idler Gear (Large)	1.5	26	
Roller Gear	(G)	13001B	Gear	1.5	12	
	(H)	13010B	Gear	1.5	12	

(2) Capability

Processing Cycle Time(Sec.)		90	120	180
Transporting Speed(mm/min)		460	350	236
Capability (sheets/hour)	24 x 30cm(10 x 12 inch)	75	70	55
	35 x 43cm(14 x 17 inch)	60	55	40

NAME OF PARTS

3) Adjusting the Drive Timing Belt

- ① Remove the Top Cover, the Right Side Panel and the Back Panel.
- ② Test the tension in the timing belt with a push-pull gauge at a point half way between the main drive shaft pulley and the drive motor pulley. Adjust the belt tension by loosening the drive motor and moving it up or down. Proper timing belt tension is in a range between loads of 75 and 125 grams with approximately 2 mm of slack in the belt. Refer to the diagram below.
- ③ Wind the rotor located on the back side of the motor mounting 3 times, then check the belt tension once more to make sure that it is still in a range between loads of 75 and 125 grams with approximately 2mm of slack in the belt.
- ④ Repeat the same step of (3) eight times. If the tension falls in the above range eight times in a row, the adjustment has been successfully completed. If even one test result falls that range, the whole adjustment procedure must be repeated from the beginning.

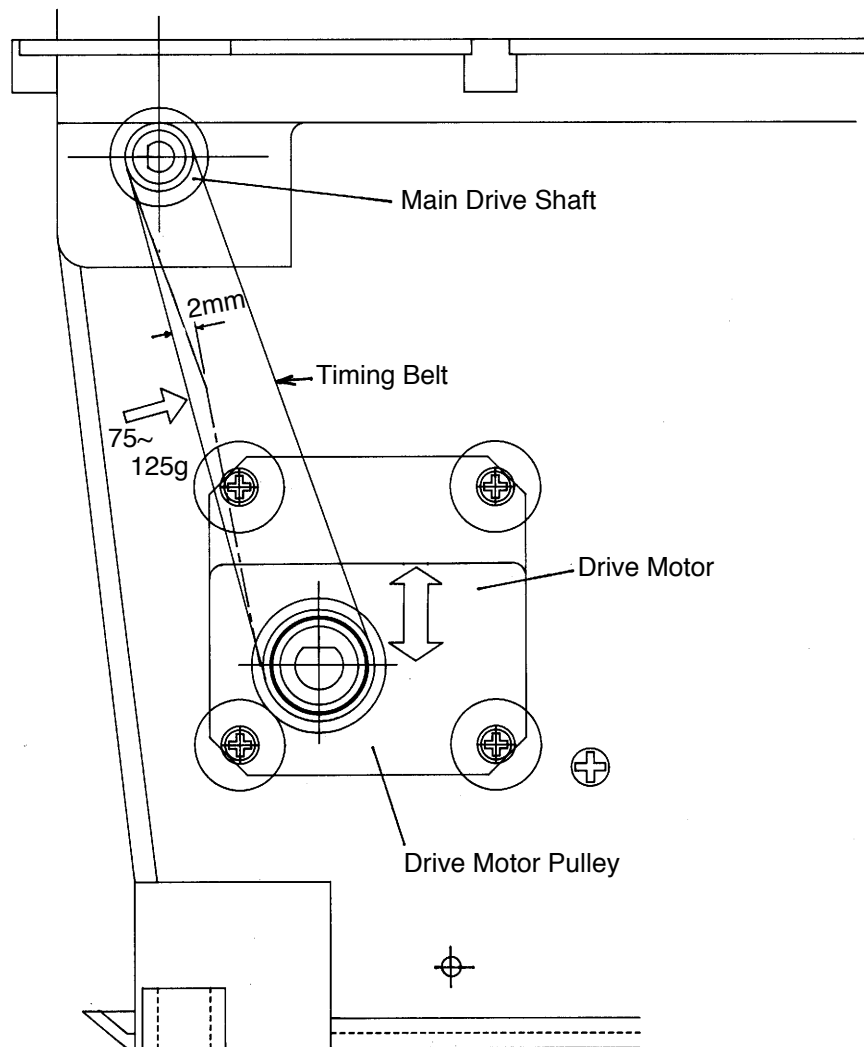

From the rear side of the processor

3-8. Solution Supply and Drainage Unit

1) Components Diagram (Bottom of the Main Unit)

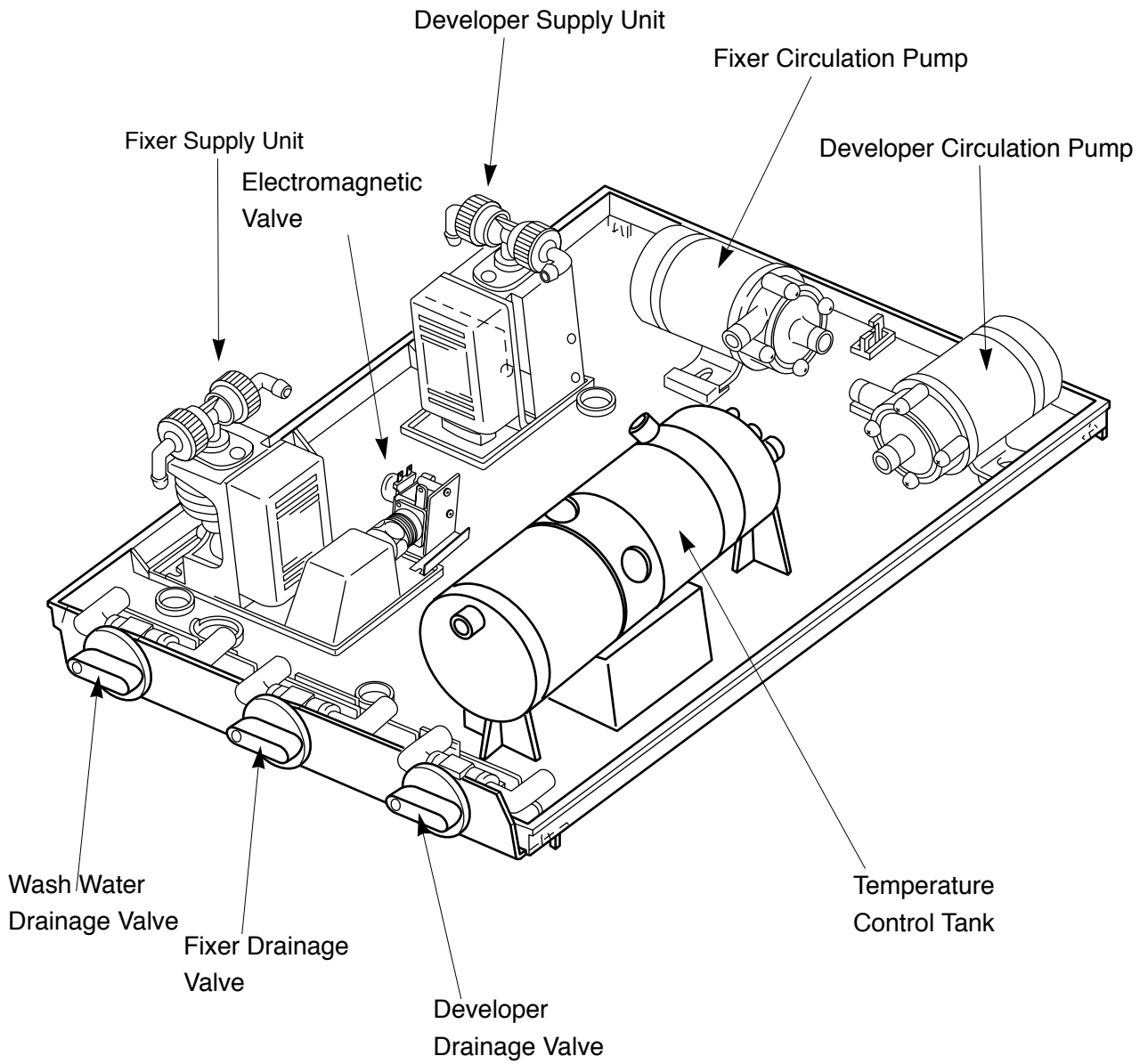

NAME OF PARTS

2) Piping Diagram

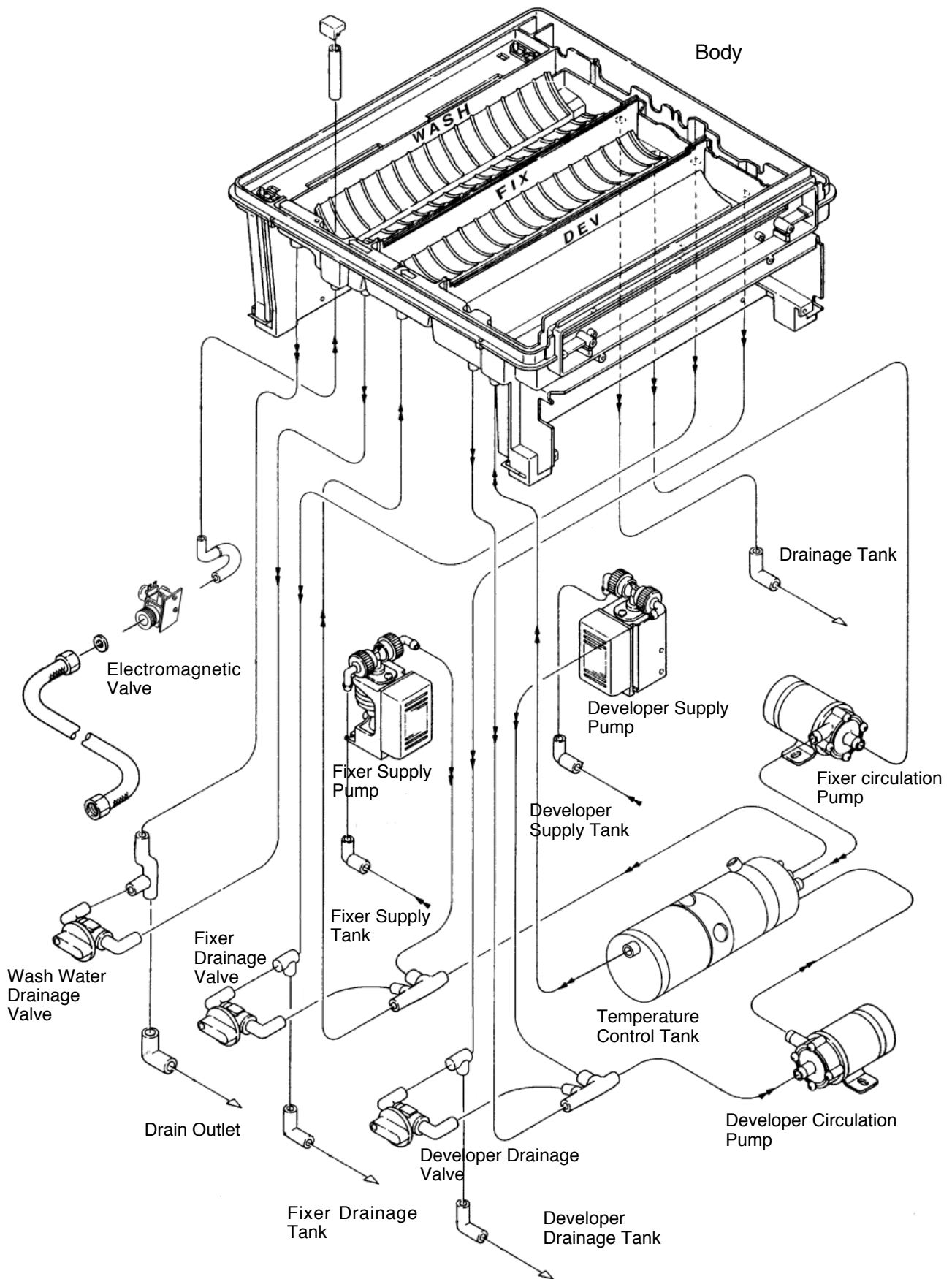

3) Solution Temperature Control Tank

(1) Components Diagram

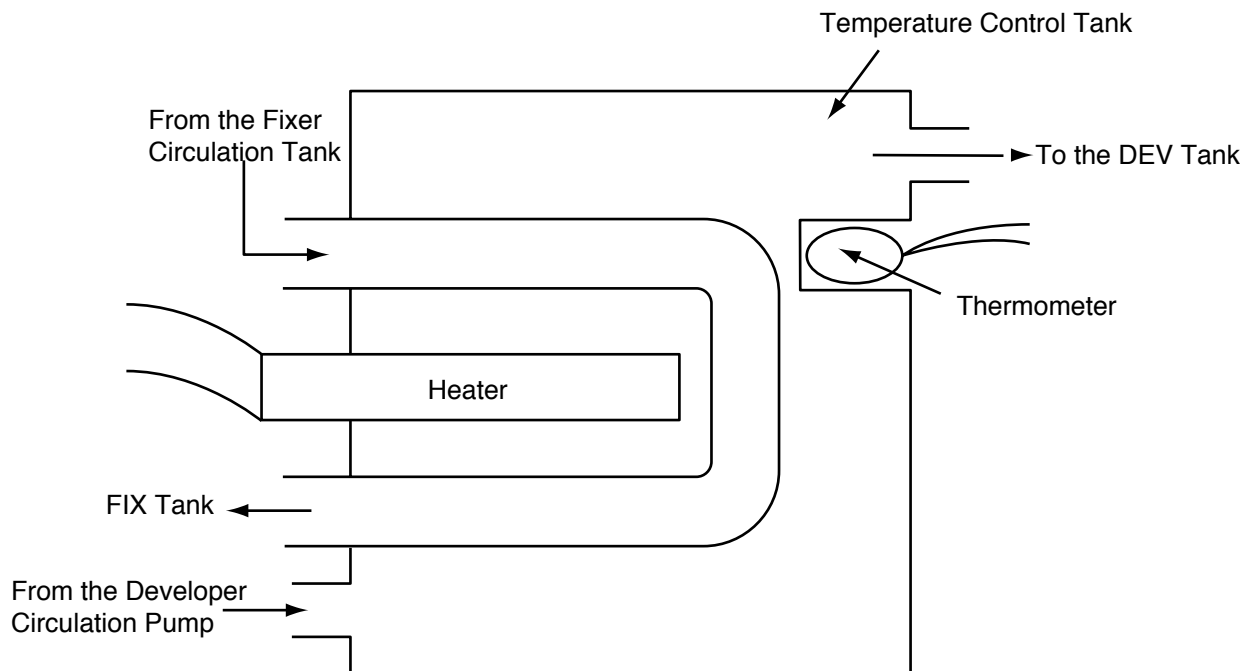

(2) Capabilities

- ① Developer temperature control is carried out by warming with a heater and by natural cooling.
- ② Fixer temperature is maintained by means of heat transferred from the developer temperature control tank.
- ③ Circulation volumes :
 - At 50 Hz : Developer 4.0 liters ; Fixer 4.0 liters/minute
 - At 60 Hz : Developer 4.8 liters ; Fixer 4.8 liters/minute
- ④ Rates of Temperature Rise :
 - Developer : approx. 1.07°C/minute
 - Fixer : approx. 0.75°C/minute
- ⑤ Sensor Precision :
 - Developer : $\pm 0.5^{\circ}\text{C}$ at settings between 32°C and 34°C.

NAME OF PARTS

3-9. Electrical Components Unit

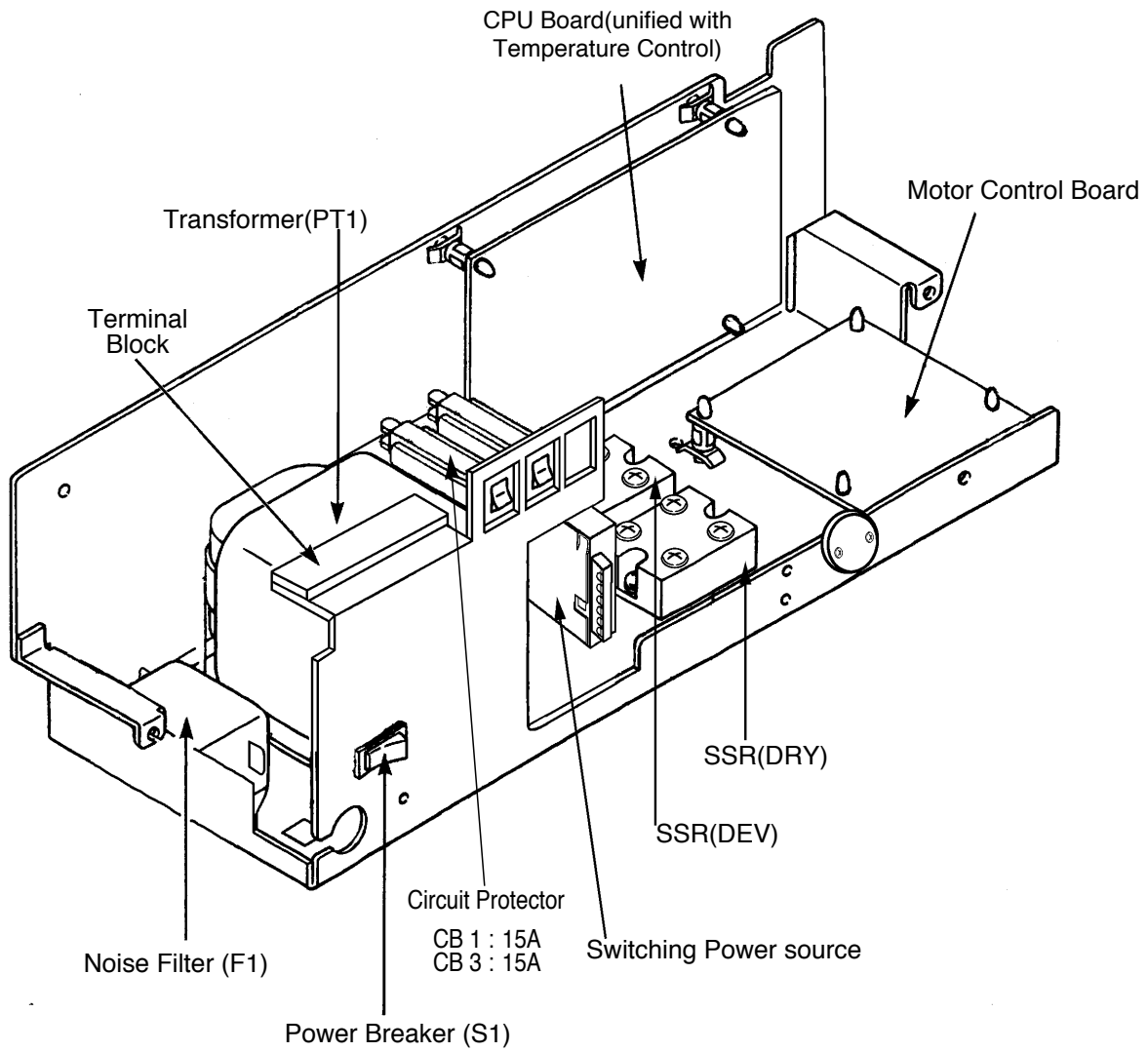

3-9. Electrical Components Unit

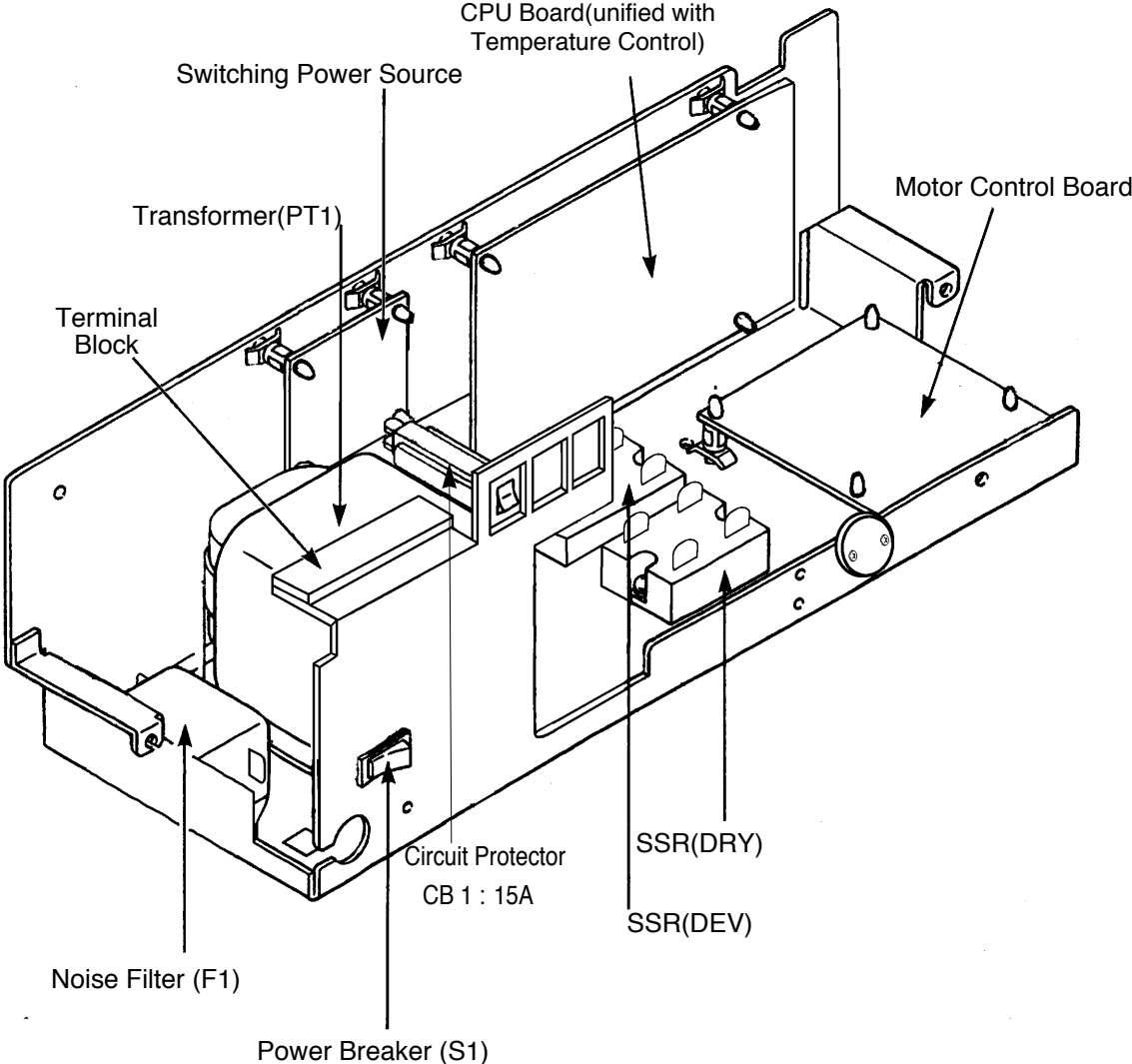

NAME OF PARTS

3-10. Film Insertion Unit

※ A rib has been added to the processing tanks so that the Guide has been unified.

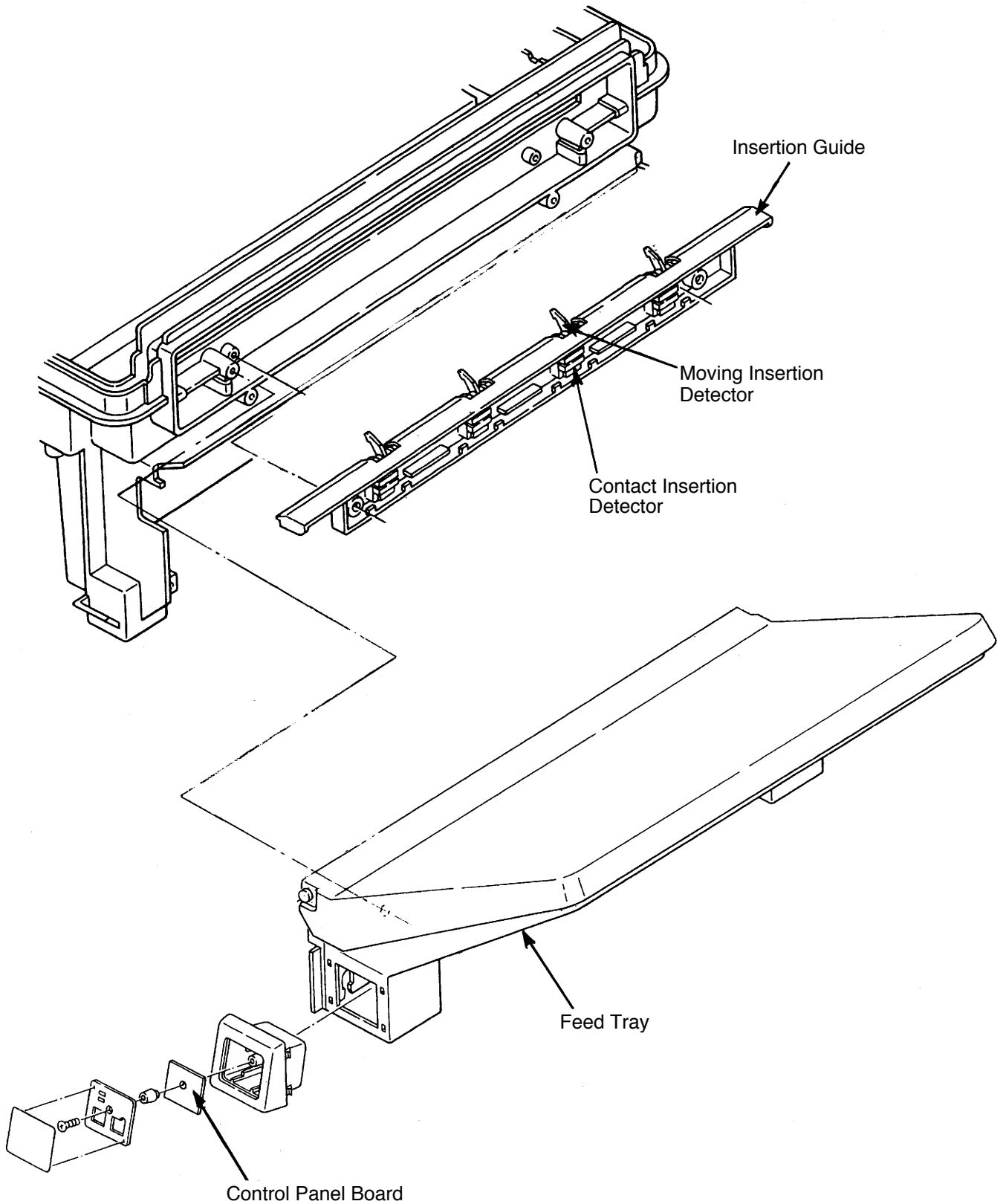

4. Time Chart (In normal functioning)

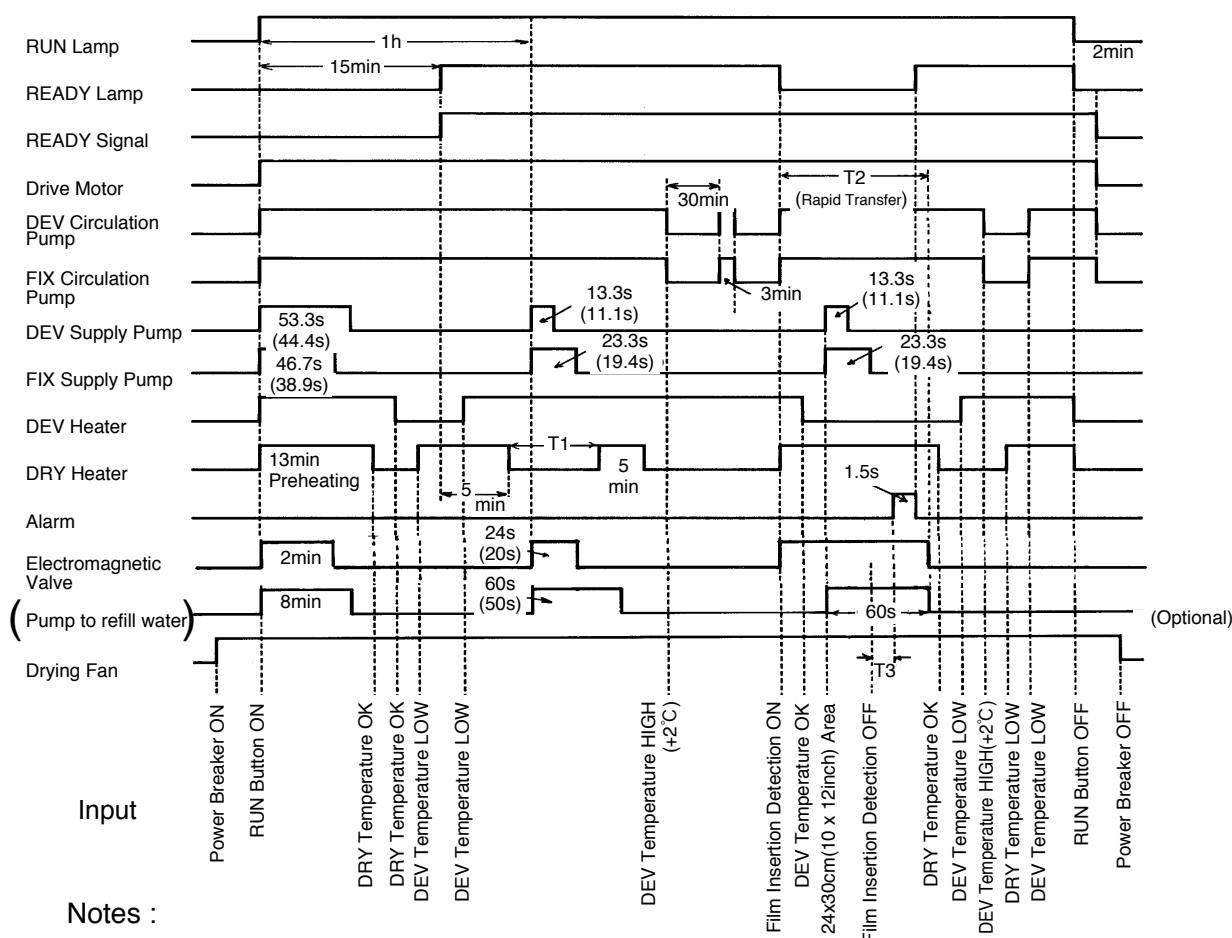

- 3)The time in the chart is valid at the 50 Hz. () is at the 60 Hz.
- 4)For each hour after RUN Button ON during which no film is processed, one 24 x 30cm(10 x 12inch) replenish amount of processing solution will be supplied to each tank. (The timer is reset after Film Insertion Detection ON.)
- 5)Drying heater preheating will begin if the temperature is below 80°C at RUN Button ON.
- 6)Initial solution replenish will not be carried out if the RUN button is pressed ON within 4 hours after RUN Button OFF.
- 7)Initial solution replenish (developer ; 26.7 sec(22.2 sec ; 60 Hz)(two 24 x 30cm(10 x 12inch) Sheets equivalent) ; fixer solution : 23.3 sec (19.4 sec : 60 Hz)[one 24 x 30cm(10 x 12inch) Sheet equivalent] will be carried out if the RUN button is pressed ON more than 4 hours after RUN Button OFF.
- 8)Even if DEV and DRY is ready, READY lamp doesn't lit at least 15 minutes.
- 9)Shutdown will occur automatically if film isn't inserted for more 8 hours after READY lamp ON.

5. TROUBLESHOOTING

5-1. Motor and Preset Temperature Errors

In this SRX-101A, the motor error or the Temperature error will be indicated by the control panel lamps and an alarm buzzer. When such errors occur, use the following listing to correct these errors. The other errors will not displayed, so these errors have to be dealt with in the next sections. (When errors occur, be sure to turn off the power source (S1))

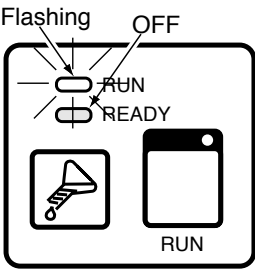
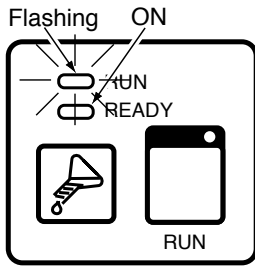
Error	Display	Cause	Response	Reset or Set Direction
Motor	<p>The RUN lamp will begin flashing, the READY lamp will go out, and the alarm will sound.</p> 	The rack drive motor is being overloaded.	<ol style="list-style-type: none"> ① Check to see if there is film or some foreign object jammed in the rack rollers or gear mechanisms. ② The rack rollers and gears may not be rotating smoothly due to shaft supports worn down by built up processing solution crystals. ③ Is the drive motor damaged? ④ Is AC 24V\pm10% being supplied to the motor control board? 	<p>Set</p> <ol style="list-style-type: none"> ① The range of motor cycle is over 10% (LOK signal ON) for three seconds. ② When the over 0.83N.m torque is on the motor shaft. <p>Reset</p> <p>When the power source is OFF.</p>
Temperatures	<p>The RUN lamp will begin flashing, the READY lamp will remain lit, and the alarm will sound.</p> 	The temperature levels for the developer and/or heater have dangerously risen above the preset values, or have remained below these values for a long period of time.	<ol style="list-style-type: none"> ① Check to see if the developer is being circulated properly. ② Is the heater fan ON and functioning properly? ③ Is the room temperature around the processor exceeding 30$^{\circ}$C? ④ Check the developer and dry heater wiring damage. ⑤ Check for breaks in the connection the developer and dry sensor to the temperature control board. ⑥ Is there film jammed in the drying unit? 	<p>Set</p> <ul style="list-style-type: none"> ● About the developer temperature. <ol style="list-style-type: none"> ① Although 45 minutes has passed after the RUN Button is on, the dev. temp. does not reach set value. ② When the dev. temp. is over $\pm 3^{\circ}$C of the range of preset value for 3 minutes after the Ready Lamp is on. <ul style="list-style-type: none"> ● About the dry temperature. <ol style="list-style-type: none"> ① Although 45 minutes has passed after the Run Button is on, the condition is not ready. ② When the dry temp. is lower than 210$^{\circ}$C although 25 minutes has passed after it is over 210$^{\circ}$C. (Once it is over 250$^{\circ}$C, the 25 min. timer is canceled.) ③ After the Run Button is on, the over 270$^{\circ}$C keeps for 3 minutes. ④ While Ready lamp is on and film is processed, over $\pm 20^{\circ}$C of the preset value keeps for 3 minutes. ⑤ While Ready lamp is on and film is not processed, 160$^{\circ}$C $\pm 20^{\circ}$C keeps for 3 minutes. <p>Reset</p> <p>When the power source is off.</p>

5-2. TROUBLESHOOTING : FLOW CHARTS

No.	Problem	Page
1	Processor will not start up (RUN lamp will not come on)	23
2	Developer circulation pump not operating.	24
3	Fixer circulation pump not operating.	25
4	Drying fans not operating.	26
5	Electromagnetic valve not operating.	27
6	Developer supply pump not operating.	28
7	Fixer supply pump not operating.	29
8	Drive motor not operating.	30
9	Drive motor will not shut off.	31
10	Developer temperature too low.	32
11	Developer temperature too high.	33
12	Drying temperature too low.	34
13	Drying temperature too high.	35
14	Supply pumps will not respond to electrical cycle change.	36
15	Initial or replenish solution supply not operating properly.	36
16	Supply pumps will not shut OFF.	36
17	READY light will not come ON.	37
18	READY light will not turn OFF.	37
19	Film insertion alarm will not sound.	38
20	Film insertion alarm will not turn OFF.	38
21	Processor will not switch over to the Standby Mode.	39
22	Processor will not switch out of the Standby Mode.	39

TROUBLE SHOOTING

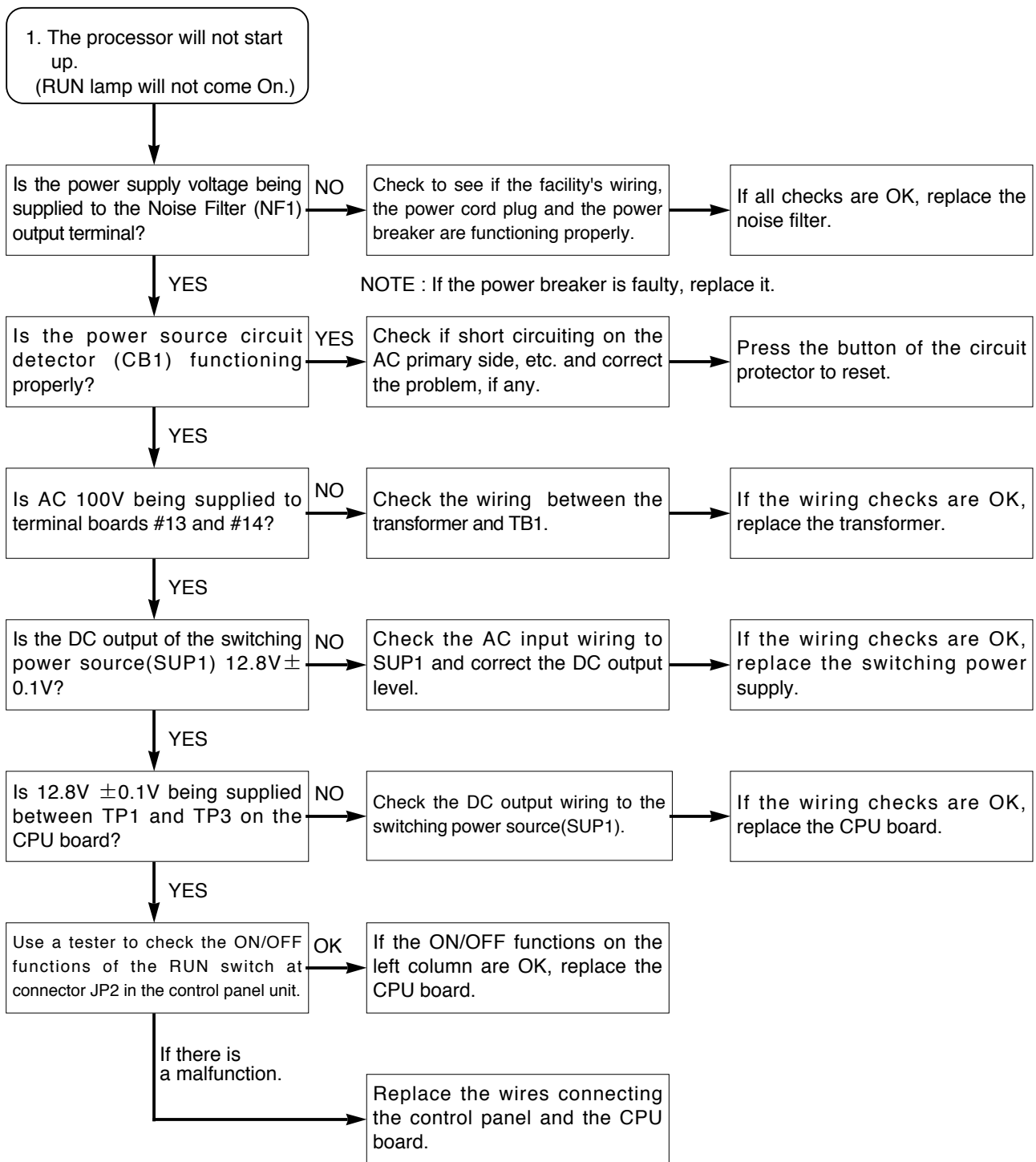

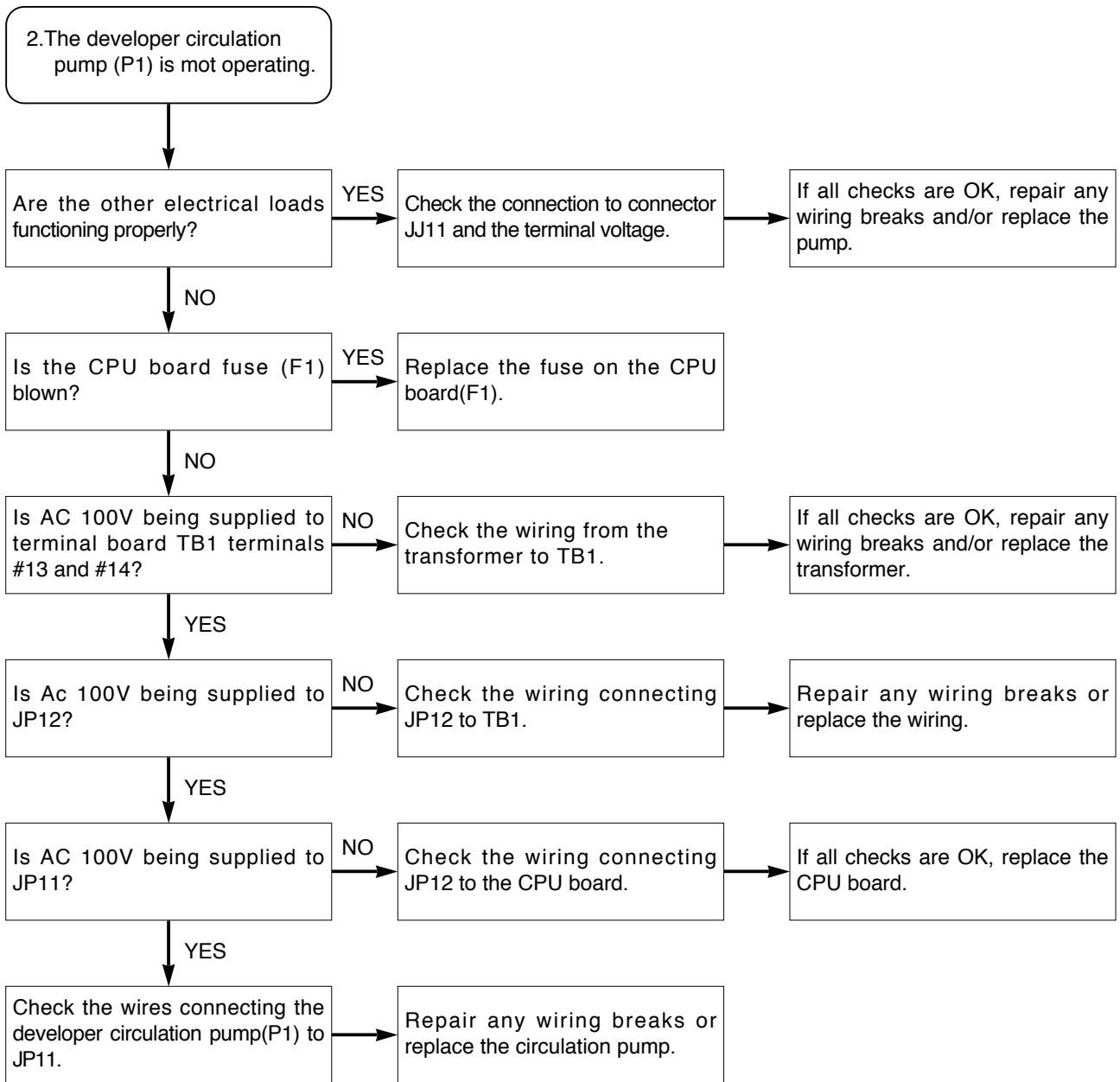

TROUBLE SHOOTING

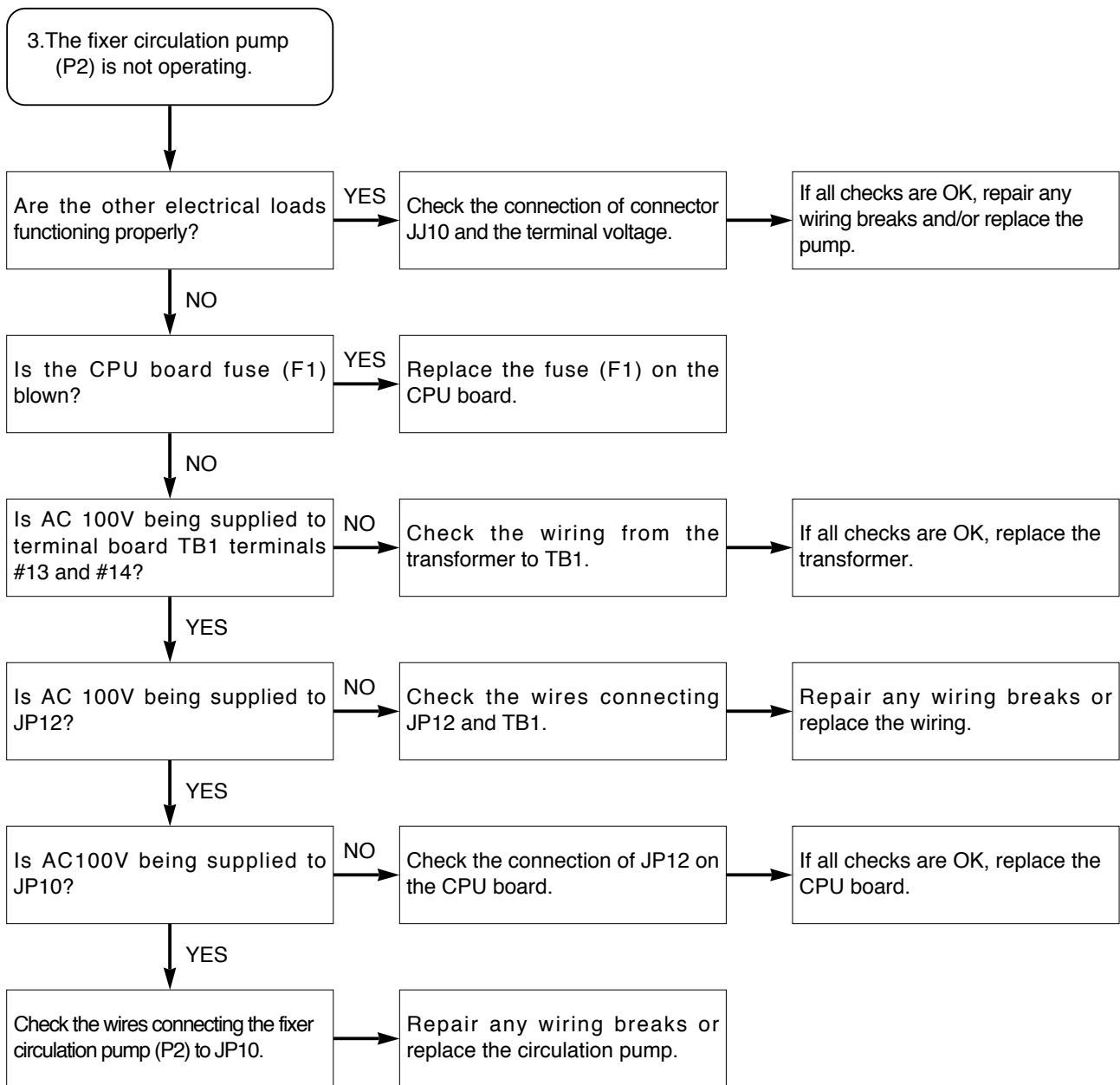

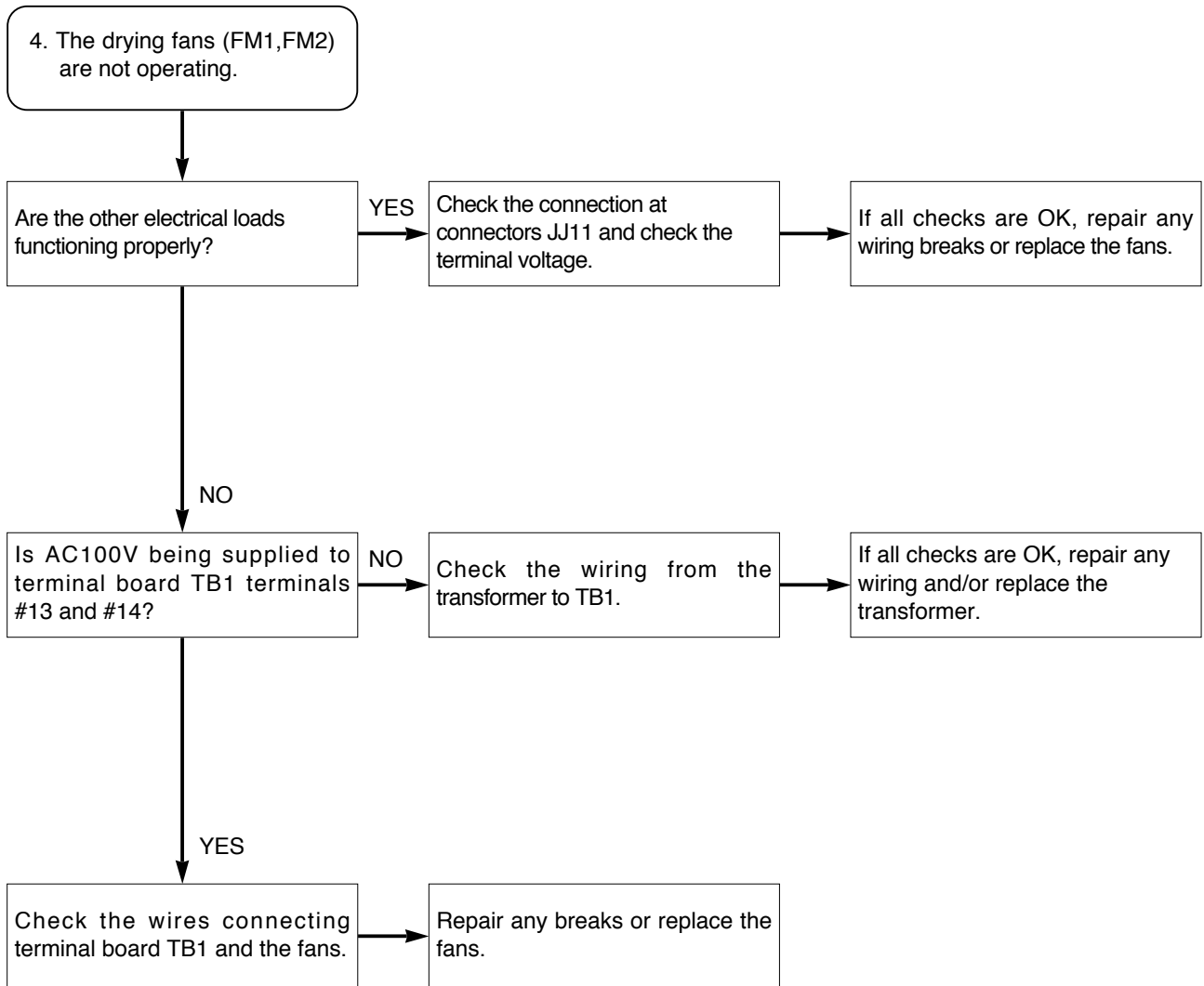

TROUBLE SHOOTING

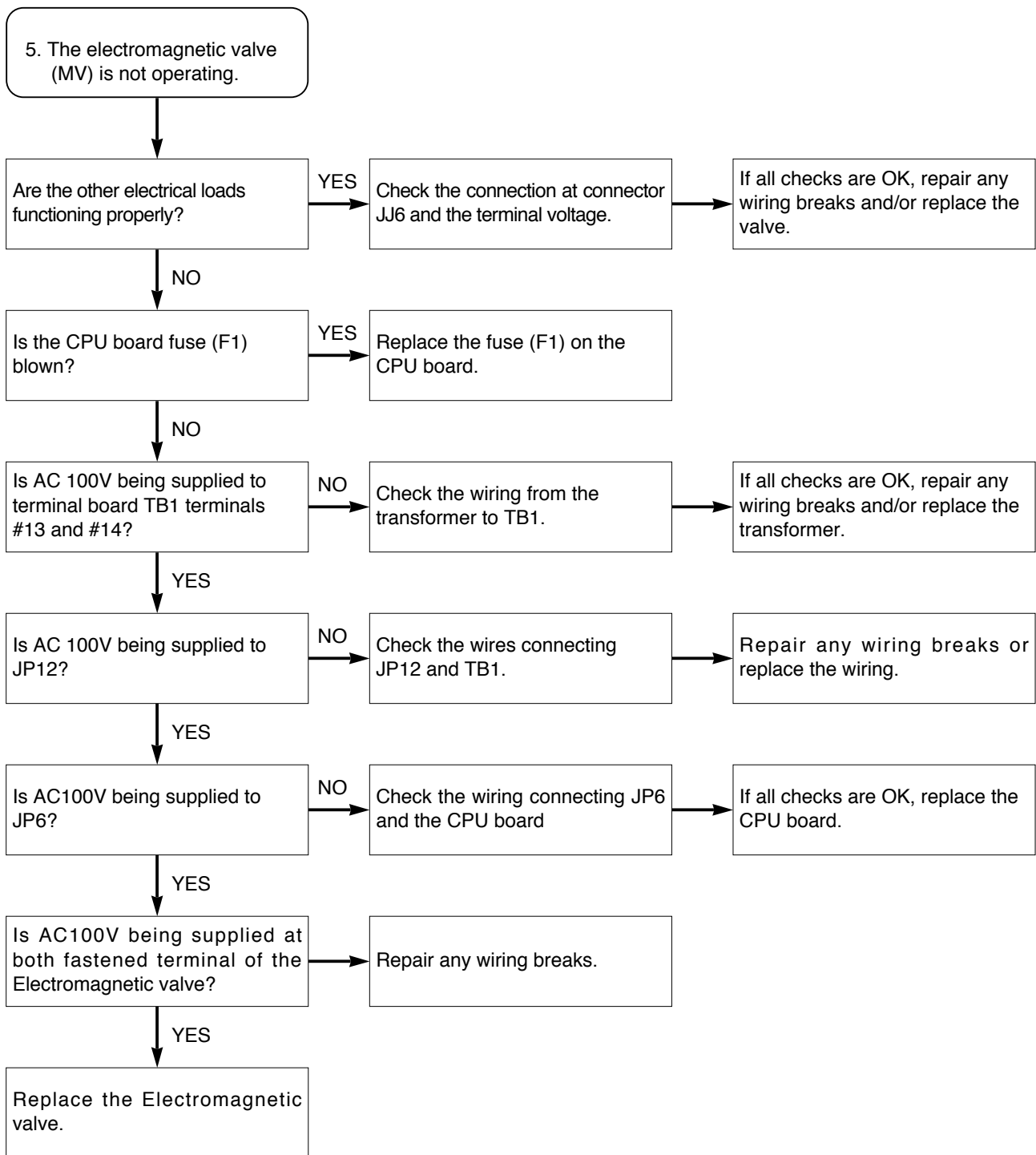

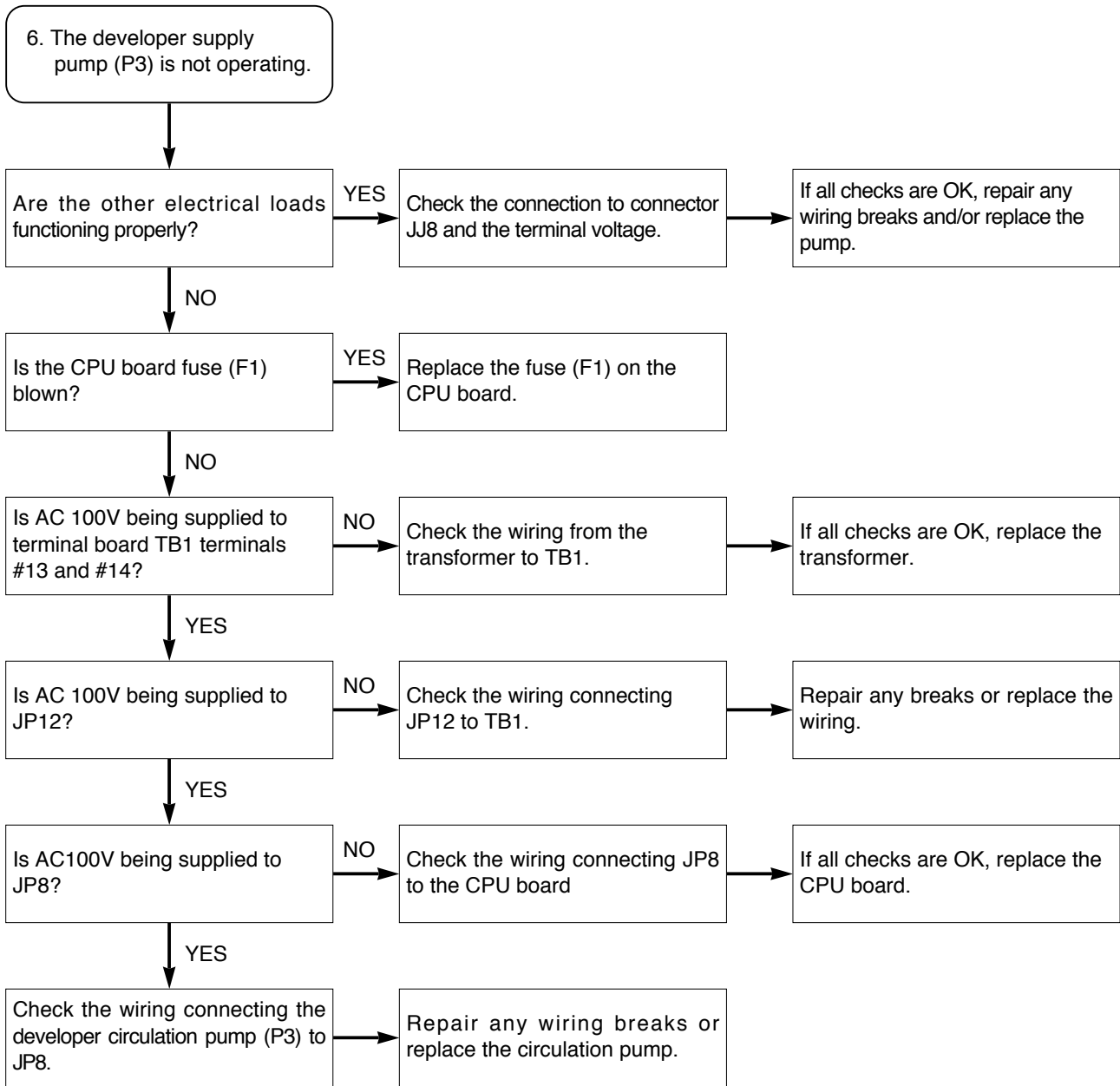

TROUBLE SHOOTING

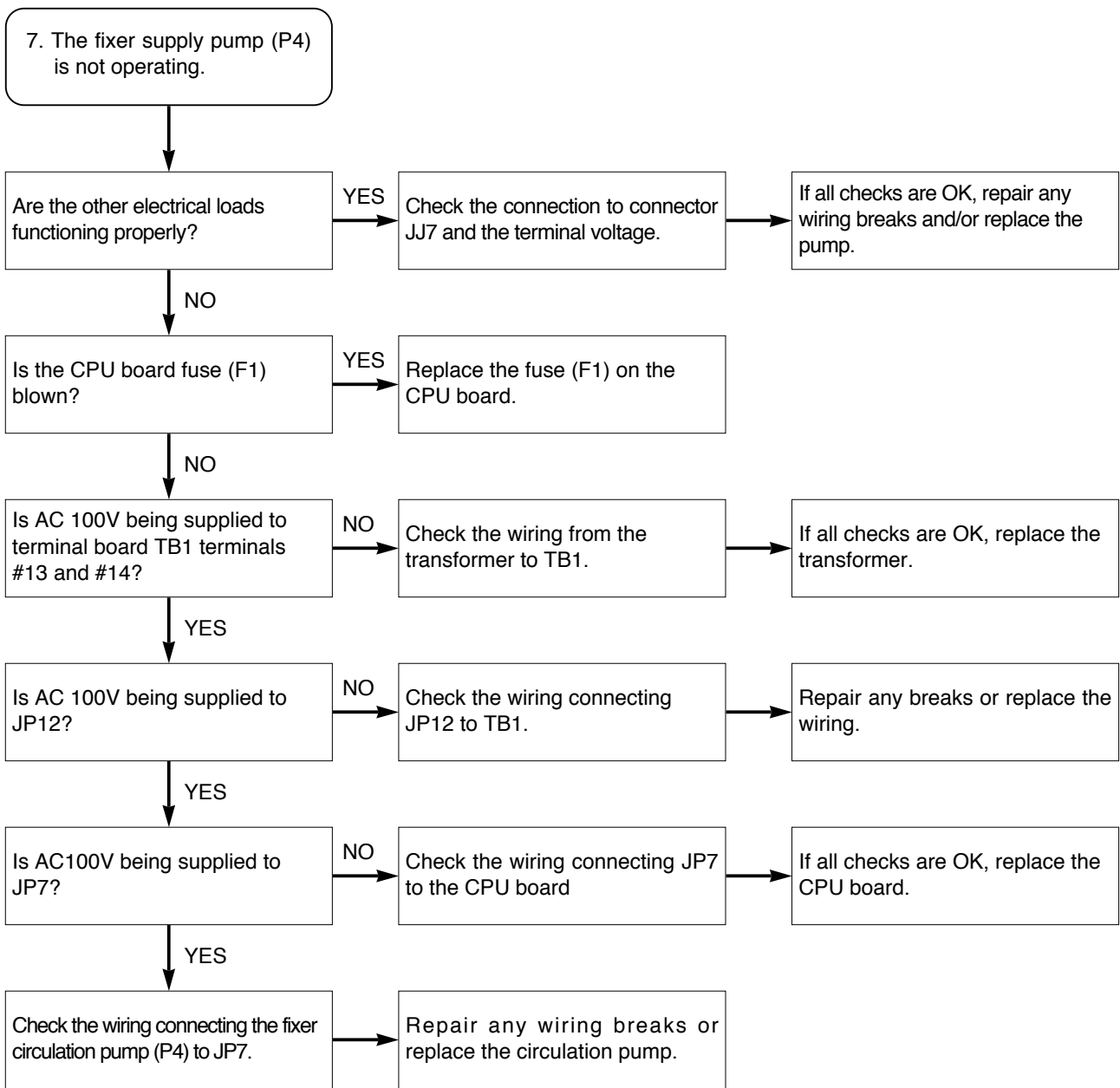

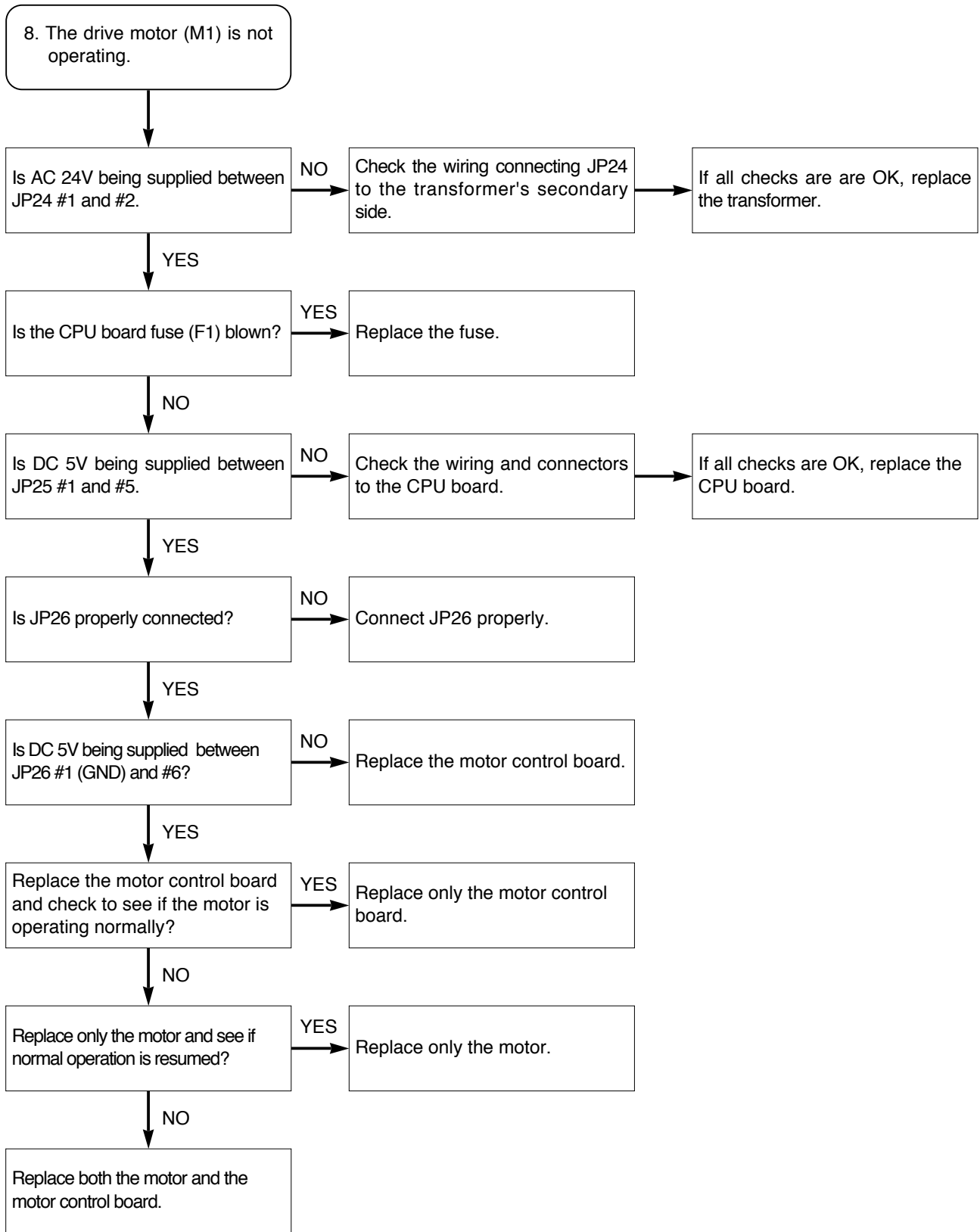

TROUBLE SHOOTING

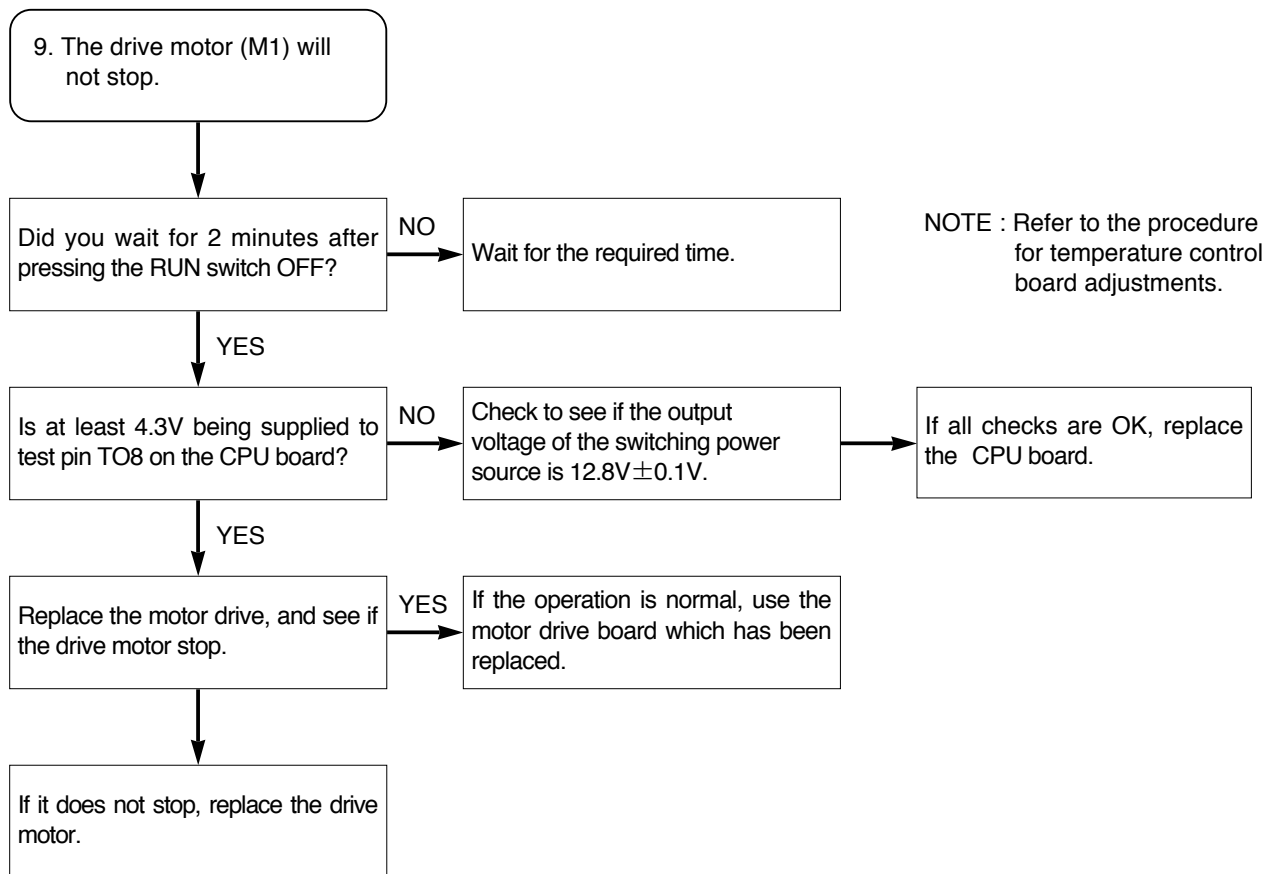

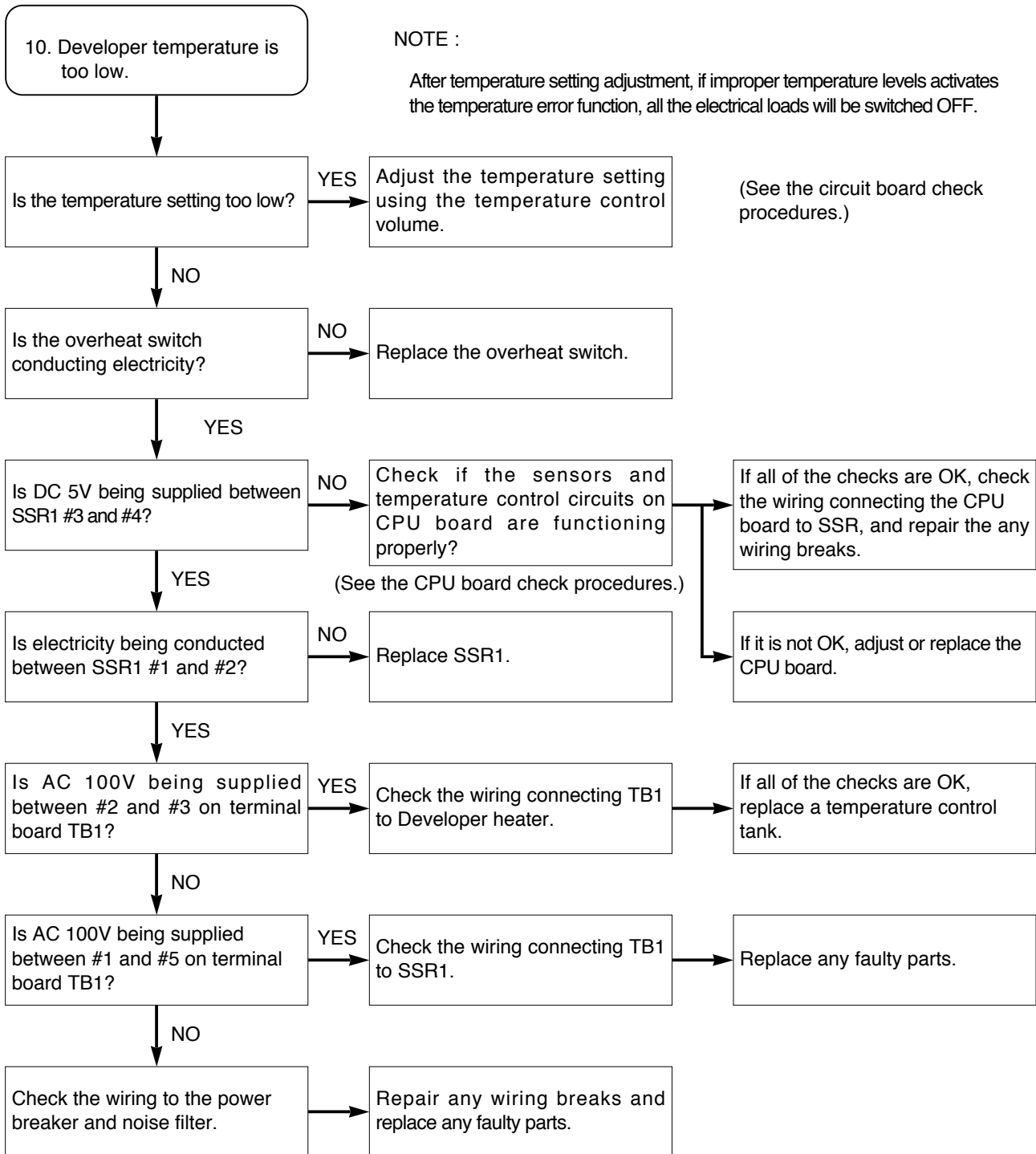

TROUBLE SHOOTING

NOTE :

After temperature setting adjustment, if improper temperature levels activates the temperature error function, all the electrical loads will be switched OFF.

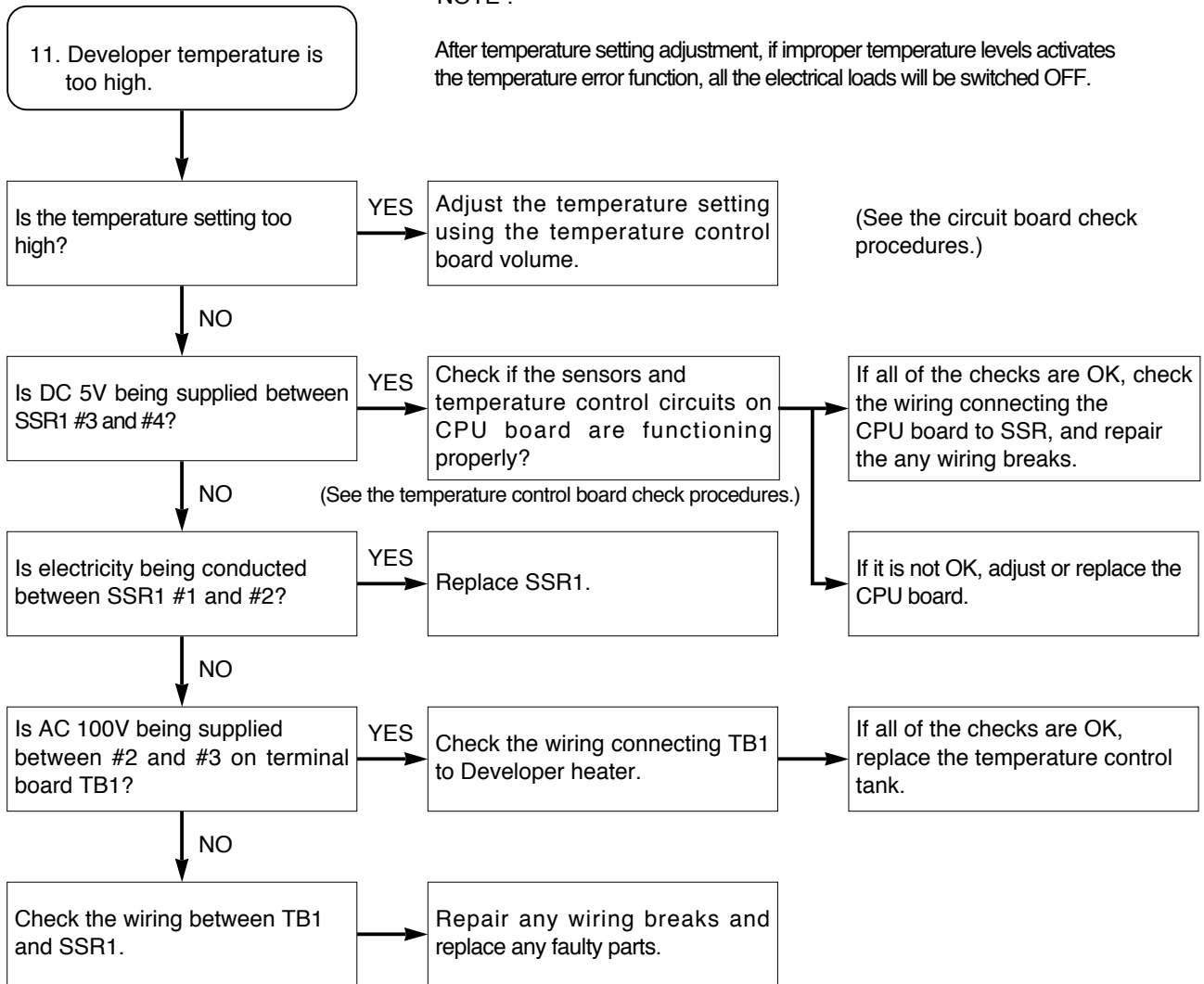

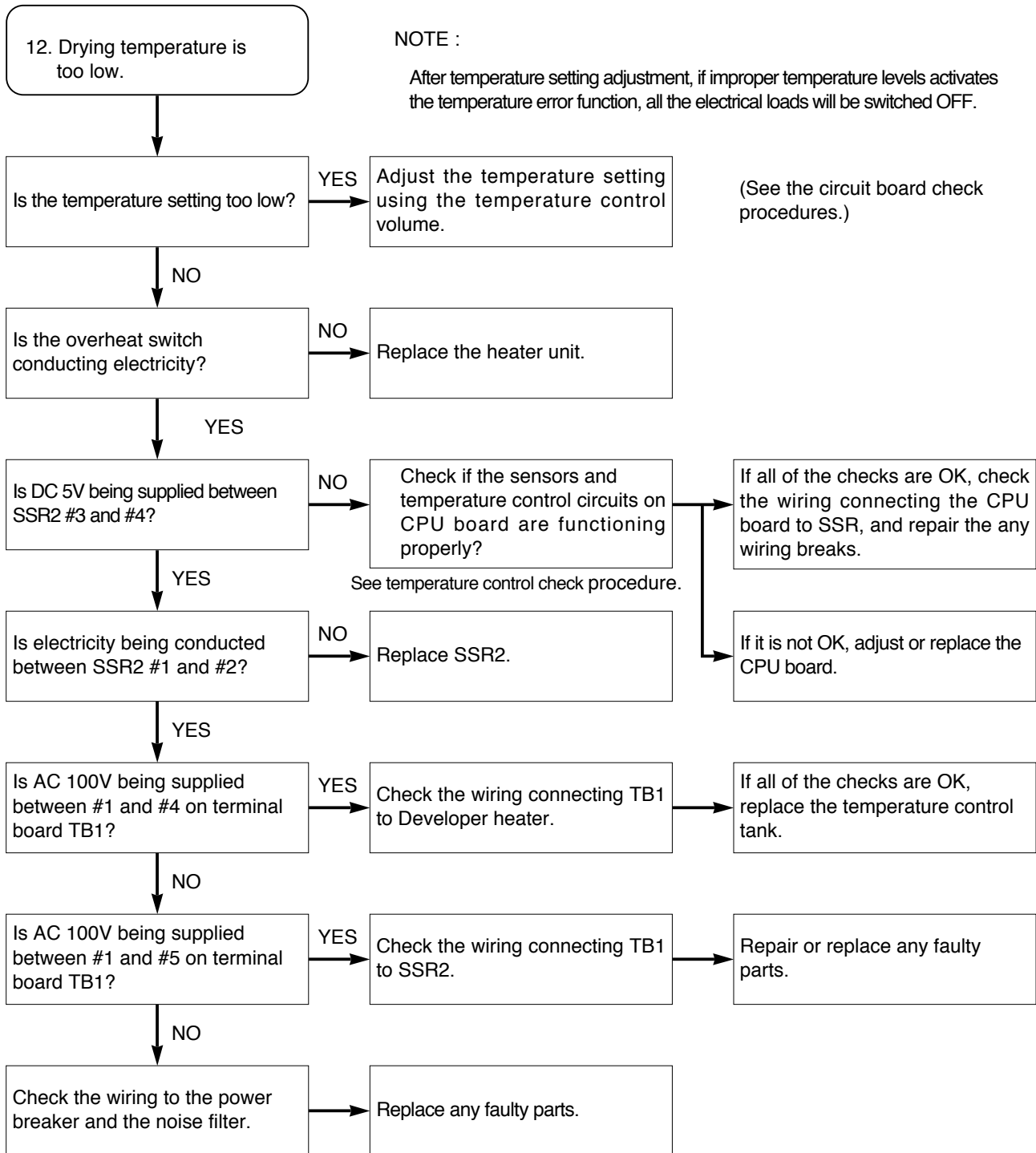

TROUBLE SHOOTING

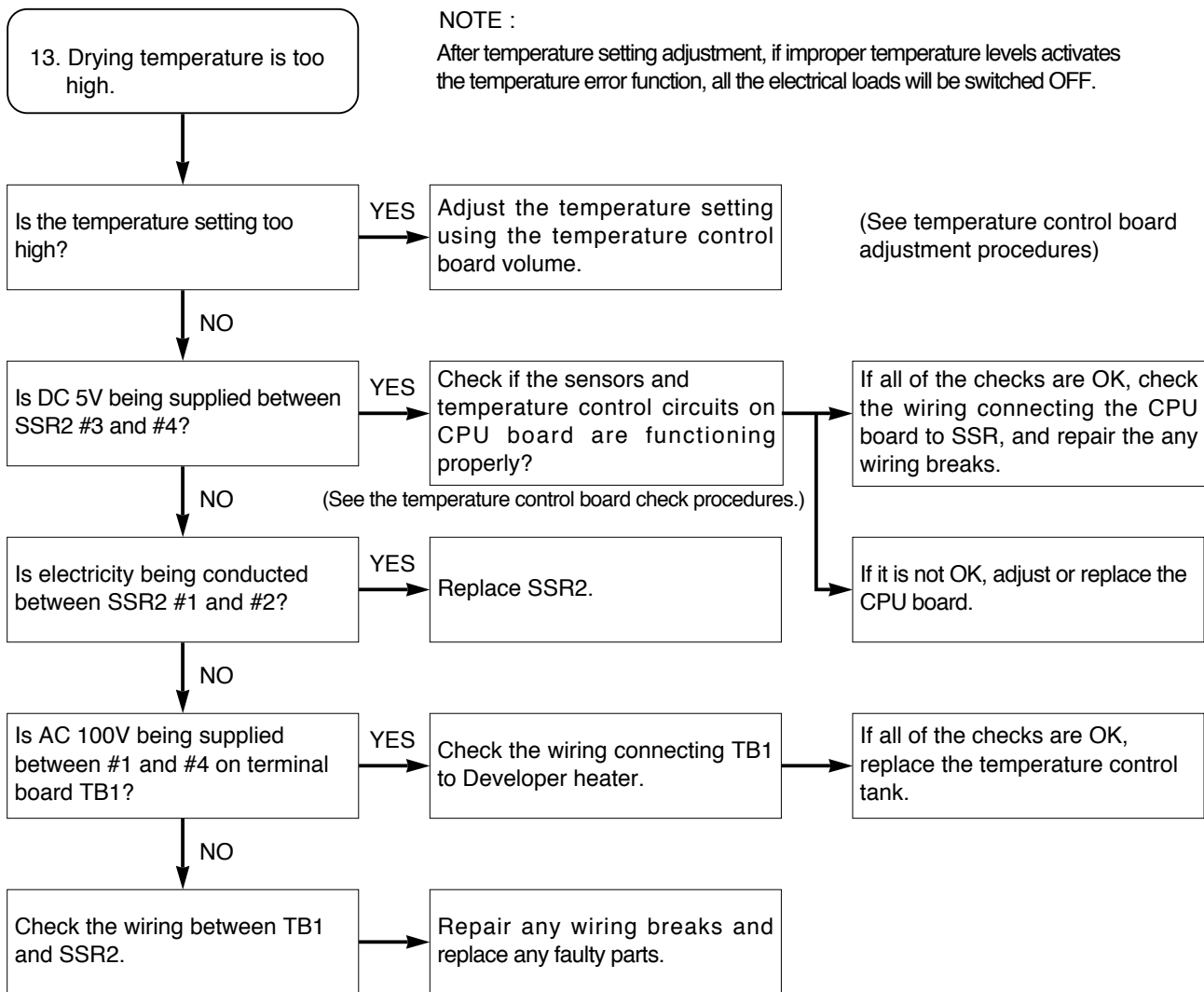

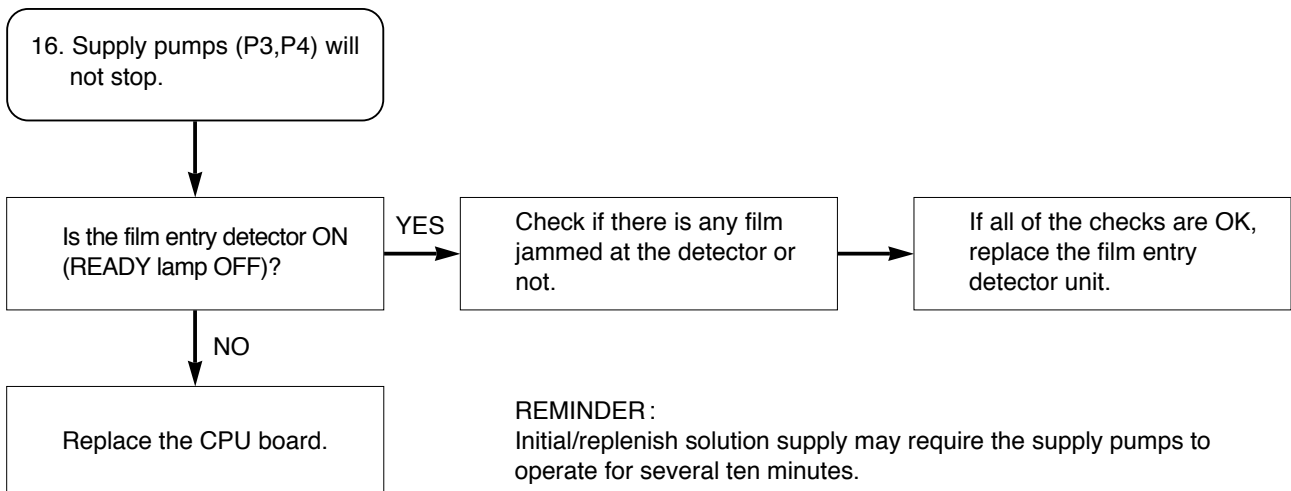
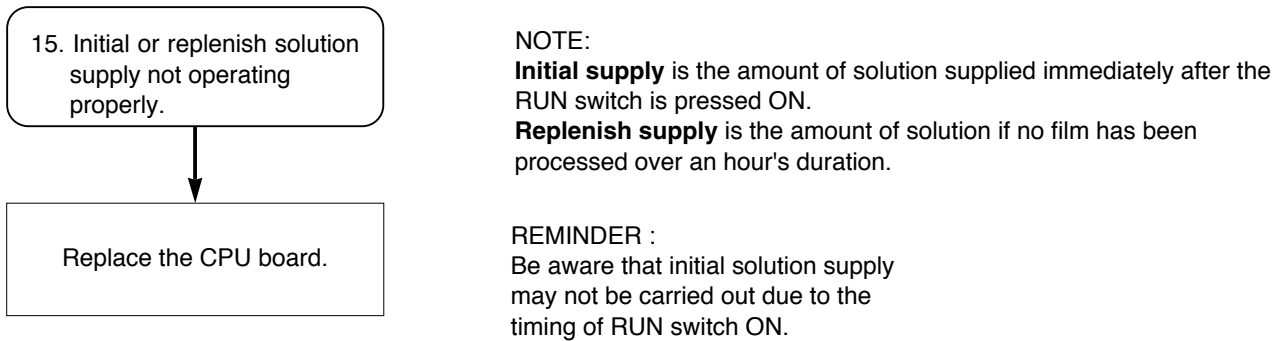
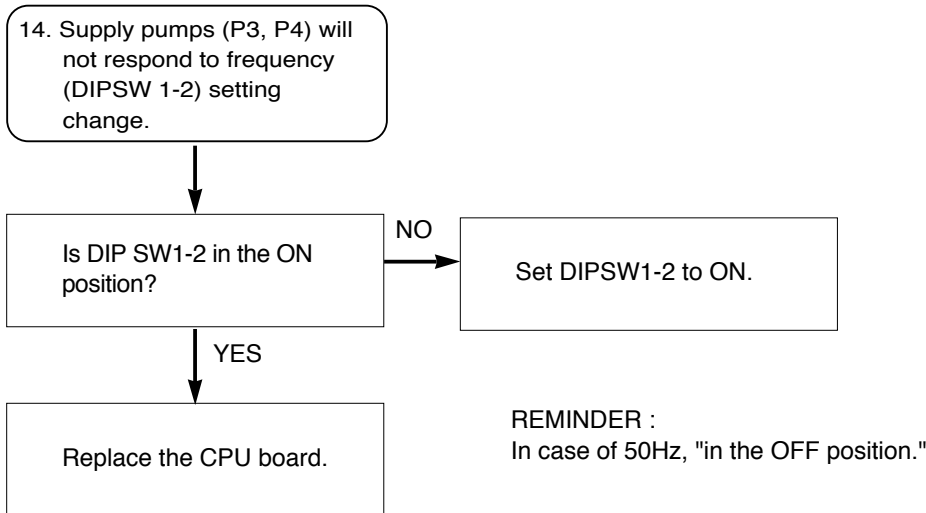

TROUBLE SHOOTING

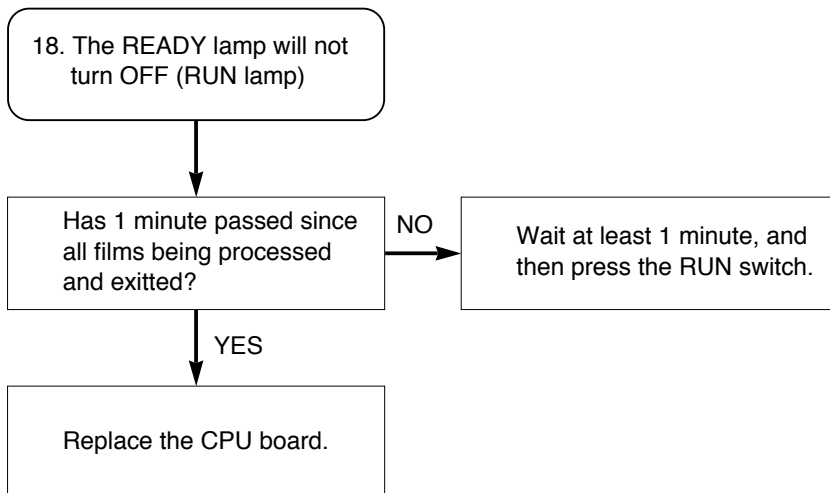
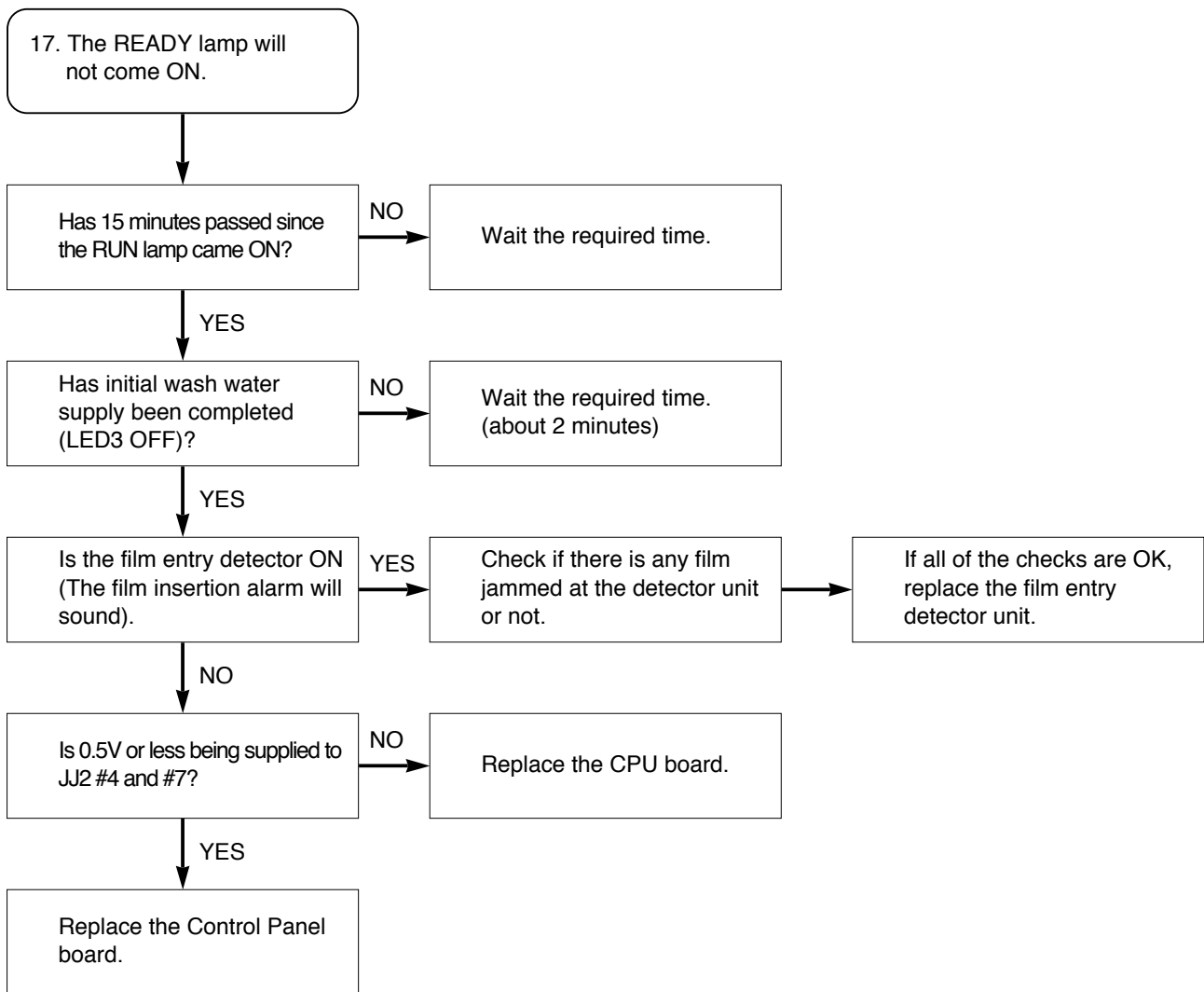

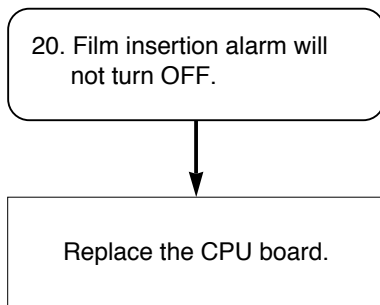
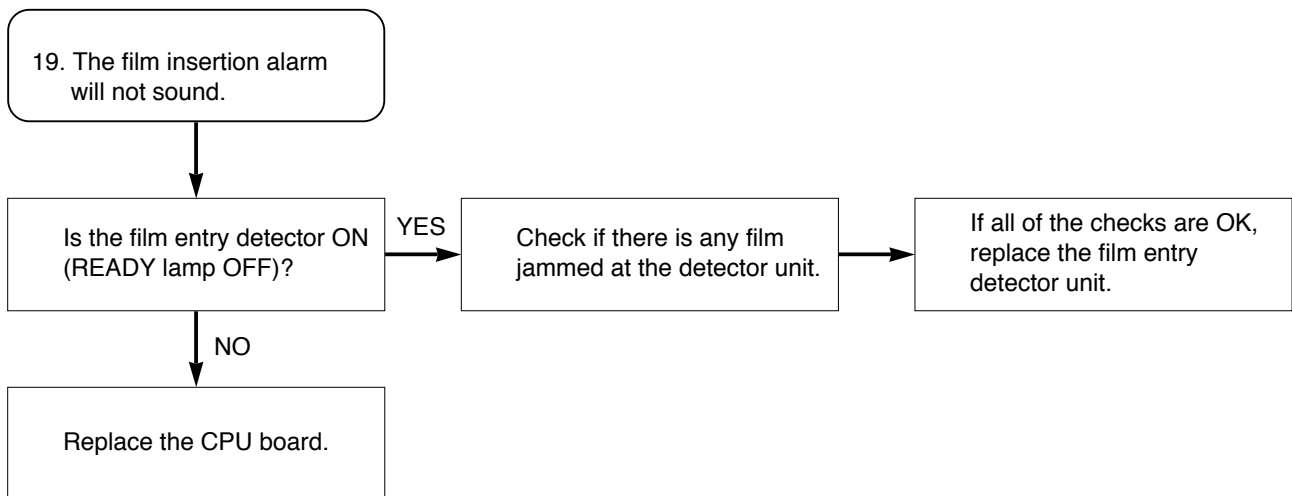

REMINDER :
The alarm sounds intermittently whenever an error occurs.

TROUBLE SHOOTING

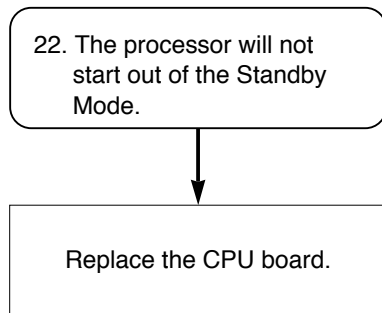
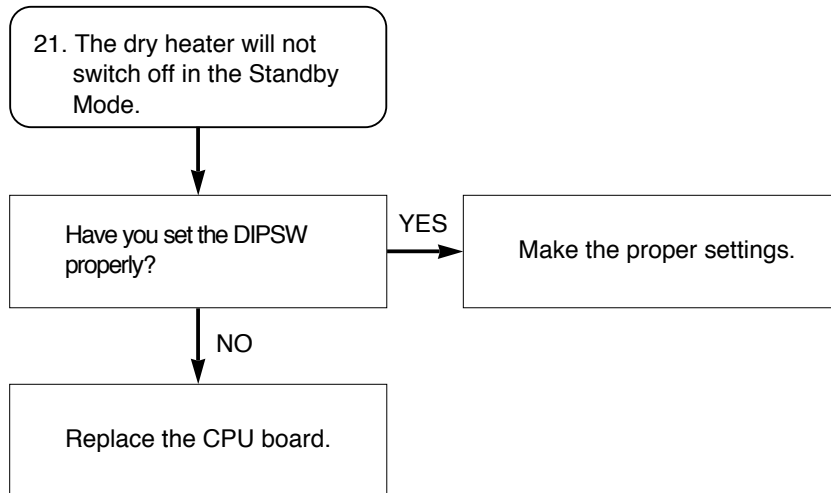

REMINDER:
Check to see if the drying heater is functioning properly (See FLOW CHART 12)

5-3. Trouble Caused by the Film Processor

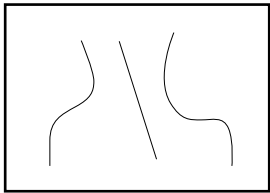
No.	TROUBLE	CAUSE	RESPONSE	ADVICE To CUSTOMER
1	The processed film surface is coming out grimy.	<ul style="list-style-type: none"> • The processing tank rollers are dirty. • The processing solutions are dirty. • The wash water is dirty. • The cleaning film maintenance procedure is not being properly carried out. • The film holder in the feed tray is dirty. 	<ul style="list-style-type: none"> • Clean the rollers. • Replace the processing solutions. • Clean the processing tanks. • Check the wash water level. • Replace the electromagnetic wash water supply valve if damaged. • Clean the feed tray film holder. 	<ul style="list-style-type: none"> • Remind about checking and maintenance tasks. • Remind about the cleaning film procedures.
2	The film is coming out damaged.	<ul style="list-style-type: none"> • Improperly set or damaged processing racks. • Improperly set or damaged drying racks. • There are pointed or edges damaged areas in the feed tray film holder. • Damaged guides in the processing tanks. • Rollers have not been set properly in their racks. • Improper roller rotation. • Improperly set drive shaft. • Loose or damaged roller pressure springs • Damaged gears. 	<ul style="list-style-type: none"> • Set the racks properly in place. • Repair the damaged or replaced the racks. • Set the rack properly. • Repair the damage or replace the rack. • Repair the damaged area. • Replace the tray. • Clean the film holder. • Repair the damaged guide. • Set the rollers properly. • Replace any damaged drive shaft supports. • Check if the drive shaft supports are set properly. • Set the springs properly in place. • Replace damaged springs. • Replace damaged gears. 	<ul style="list-style-type: none"> • Show the proper method for setting the racks using the guide arrows. • Show the proper method for setting the rollers.
3	Uneven developer (1) Poor solution circulation 	<ul style="list-style-type: none"> • Damaged or worn developer circulation pump (P1). • Damaged circulation pipe lines. • Blocked circulation pipe lines. 	<ul style="list-style-type: none"> • Replace the pump. • Repair the pipe line. • Clean the pipe line. 	

TROUBLE SHOOTING

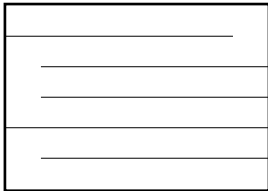
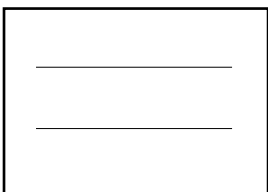
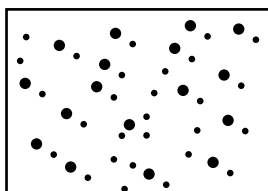
No.	PROBLEM	CAUSE	RESPONSE	ADVICE To CUSTOMER
	(2) Bands across the film perpendicular to the direction of film transport. 	<ul style="list-style-type: none"> • Improper roller rotation. • Dirty rubber rollers. • Film slippage in the rollers. 	<ul style="list-style-type: none"> • Check the film transport mechanism. • Clean the rollers. • Make sure all of the moving parts are set properly. • Replace all damaged parts. 	<ul style="list-style-type: none"> • Remind about the periodical check and maintenance. • Show the proper method for setting the rollers. • Show the proper method for setting the racks using the guide arrows.
	(3) Black streaks 	<ul style="list-style-type: none"> • Improper roller rotation. • Dirty rubber rollers. • Film slippage in the rollers. 	<ul style="list-style-type: none"> • Check the film transport mechanism. • Clean the rollers. • Make sure all of the moving parts are set properly. • Replace all damaged parts. 	<ul style="list-style-type: none"> • Remind about the periodical check and maintenance. • Show the proper method for setting the rollers. • Show the proper method for setting the racks using the guide arrows.
	(4) Pressure marks 	<ul style="list-style-type: none"> • Developing rack roller surface is too rough. • Developing rack roller surface is dirty. 	<ul style="list-style-type: none"> • Replace any faulty rollers. • Clean the rollers. 	<ul style="list-style-type: none"> • Remind about when the rollers should be cleaned. • Show the proper method for cleaning the rollers.
4	Poor film developing (Poor density)	<ul style="list-style-type: none"> • Insufficient solution replenishing. • Faulty supply pump (P3). • Faulty supply line. • The developer is exhausted due to overuse. • Incorrect developer temperature. 	<ul style="list-style-type: none"> • Replace the faulty parts. • Replace the developer solution. • Correct the developer temperature setting. 	<ul style="list-style-type: none"> • Remind about processing solution replacement intervals.
5	Poor fixing quality	<ul style="list-style-type: none"> • Insufficient replenishing • Faulty supply pump (P4) • Faulty supply line • The fixer is exhausted due to over use. (When processing small film lots.) • The fixer temperature is too low. 	<ul style="list-style-type: none"> • Replace the faulty parts. • Replace the fixer solution. 	<ul style="list-style-type: none"> • Remind about processing solution replacement intervals. • Show the proper method for maintaining optimum fixer temperature.

TROUBLE SHOOTING

No.	TROUBLE	CAUSE	RESPONSE	ADVICE To CUSTOMER
6	Discoloration	<ul style="list-style-type: none"> • The fixer solution temperature is too low. • The wash water temperature is too low. • The fixer is exhausted due to overuse. (when processing small film lots.) • There is no water in the WASH Water tank. 	<ul style="list-style-type: none"> • Replace the fixer solution. • Replace the faulty parts. 	<ul style="list-style-type: none"> • Show the proper method for maintaining optimum fixer temperature. • Install a water heating device. • Remind about processing solution replacement intervals. • Show checking method of the water supply valve and wash water drainage valve.
7	Insufficient drying	<ul style="list-style-type: none"> • Incorrect temperature setting. The drying heater (H1) is faulty. The drying heater fans (FM1,2) are faulty. The drying sensor (RB1) is faulty. 	<ul style="list-style-type: none"> • Correct the temperature setting. • Replace the faulty parts. 	
8	Uneven drying	<ul style="list-style-type: none"> • Incorrect temperature setting. The drying heater (H1) is faulty. The drying heater fans (FM1,2) are faulty. The drying sensor (RB1) is faulty. • The wipe-down roller is dirty. 	<ul style="list-style-type: none"> • Correct the temperature setting. • Replace the faulty parts. • Clean or replace the wipe-down roller. 	

TROUBLE SHOOTING

5-4. Trouble Caused by Improper Film Handling

PROBLEM	SYMPTOM	CAUSE	RESPONSE
Fogging	• A certain portion of the film is being blackened. (This is occurring in the same spot on a large number of sheets.)	<ul style="list-style-type: none"> • Improper light shielding of stored film (due to torn wrapping), a film cassette and the other facilities. • Gas fogging due to sulfurous gas, etc. when docked with other equipment. 	<ul style="list-style-type: none"> • Checking and repair.
	• Circular density unevenness.	<ul style="list-style-type: none"> • Fogging due to light from the photoelectric sensors. • Radiation material is attached to the film packaging. 	<ul style="list-style-type: none"> • Adjust the photoelectric detection system.
	• Traces or shadows of objects have been transferred onto the film.	<ul style="list-style-type: none"> • Improper light shielding. • Fogging due to long term exposure to a safety light whose intensity is not suited to the level of film sensitivity. • Fogging by radiation. 	<ul style="list-style-type: none"> • Checking and repair. • Use a safety light that is compatible with the film and strictly follow all precautions for its use. • Properly shield the equipment from radiation.
	• Fogging damage to every sheet of film being processed.	<ul style="list-style-type: none"> • The film is being stored under excessive temperature or humidity condition. • Fogging due to gas from painted surface in the film storage facilities. • Safelight fogging. • The film has been past over the expiration date. 	<ul style="list-style-type: none"> • Store the film in a well air conditioned and ventilated facilities. • Check the room air exhaust conditions. • Use film based on a consuming plan.
Static electricity marking	• Certain patterns shaped like a branch, dot or clouded are on the film.	<ul style="list-style-type: none"> • The film is being exposed by a source of static electricity. • The temperature around the processor is too low. • Film sensitive to electrical charge is being used. • The film is being affected by friction during handling. • The equipment is being electrically charged. • The screen is being electrically charged. 	<ul style="list-style-type: none"> • Use a humidifier to correct dry, low humidity conditions around the processor. • Use anti-static cleaners.

TROUBLE SHOOTING

PROBLEM	SYMPTOM	CAUSE	RESPONSE
Dry Pressure	<ul style="list-style-type: none"> • Unevenness due to reduction in film sensitivity. (white-outs) 	<ul style="list-style-type: none"> • Pressure has been on the film before exposure by rough handling, such as bending, jamming, or dropping. (This occurs frequently under low humidity conditions). 	<ul style="list-style-type: none"> • Checking and repair. • Handle the film more carefully.
	<ul style="list-style-type: none"> • Unevenness due to increased film sensitivity. (blackening) 	<ul style="list-style-type: none"> • Pressure has been on the film before exposure by rough handling, such as bending, jamming, or dropping. • Heavy pressure has been on the film before exposure. (This occurs frequently under high humidity condition). 	<ul style="list-style-type: none"> • Checking and repair. • Handle the film more carefully.
	<ul style="list-style-type: none"> • Straight line scratches on the film. • Minute random scratching. 	<ul style="list-style-type: none"> • The film is coming into contact with rough or sharp surfaces during transport. • Film sheets are rubbing against each other. 	<ul style="list-style-type: none"> • Checking and repair. • Minimize the amount of vibration to the boxes and magazines containing the film.
	<ul style="list-style-type: none"> • Unevenness due to increased sensitivity on one or both film edges. 	<ul style="list-style-type: none"> • The roller pressure is too high. • The roller edges are dirty. • The rollers are wrapped. (This occurs frequently under high humidity conditions). 	<ul style="list-style-type: none"> • Adjust the roller spring tension. • Clean the rollers. • Replace faulty rollers.
Poor contact between the screen and the film.	<ul style="list-style-type: none"> • Faded images. 	<ul style="list-style-type: none"> • The cassette is faulty. • The screen-film contact time is too short. • The shape of the changer's contact area is deformed. • Improper pressure of the changers. 	<ul style="list-style-type: none"> • Replace the cassette. • Allow for a sufficient contact time. (At least 3 minutes)

TROUBLE SHOOTING

5-5. Service and Maintenance Schedule

Task	Monthly	Quarterly	Semiannually	Yearly
Wash Top Cover Underside	●			
Scrub DEV and FIX/WASH racks	●			
Clean the area around processing tanks	●			
Wash DEV, FIX and WASH tanks	●			
Replace developer and fixer	●			
Wash processing tank and racks with system cleaner		●		
Replace FIX side FIX/WASH roller springs			●	
Replace DEV roller and WASH side FIX/WASH roller springs				●
Wash replenishment tanks and replenishment hoses				●

5-6. How to Use Splash Guard (Optional equipment)

Use the splash guard in the following case.

- ① When replacing the solution(s) with a measuring cup in a way other than the procedure of Operation Manual.
- ② When cleaning the processing tank(s).

To use the splash guard, fit it onto the rib located above the film insertion slot.

After the work, check if the solution contacted with the film entrance sensor or the splash guard. Thoroughly wipe it off in case if it was so.

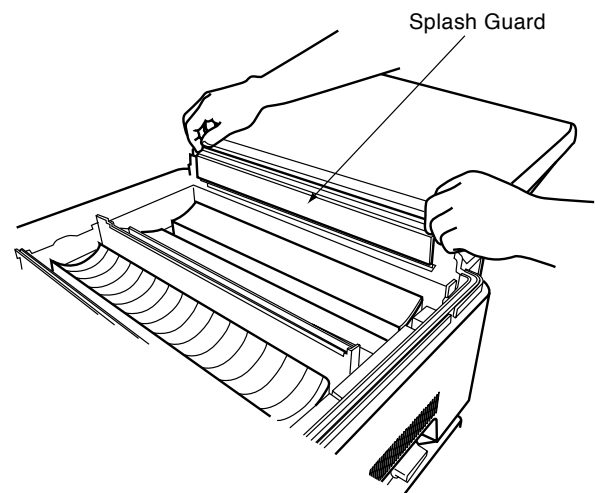

6. CPU Board DIP Switches

REMINDER : Always set the DIP switches with the processor's power breaker OFF.

DS-1

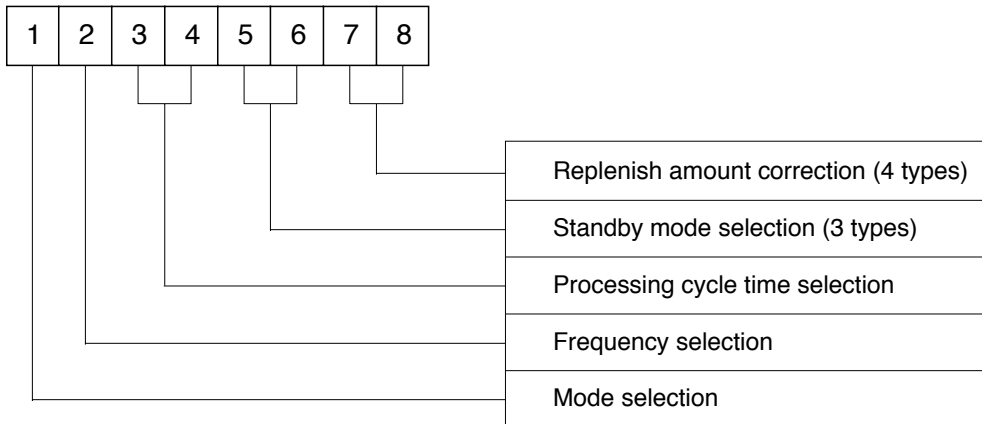

DS1-

1	Mode
OFF	Normal operating mode
ON	Maintenance mode

DS1-

3	4	Processing cycle time(Sec.)
OFF	OFF	90
ON	OFF	120
OFF	ON	180
ON	ON	Do not Use

DS1-

2	Frequency
OFF	50Hz (for CE)
ON	60Hz (for UL)

DS1-

5	6	Standby mode(min.)
OFF	OFF	0 (Continuous operation)
ON	OFF	10 (Interval)
OFF	ON	30 (interval)
ON	ON	Do not Use

7	8	Replenish amount correction
OFF	OFF	0%
ON	OFF	-20%
OFF	ON	-40%
ON	ON	+30%

CHECKING CIRCUIT BOARDS, SENSORS AND ELECTRICAL LOADS

7. Checking Circuit Boards, Sensors and Electrical Loads

REMINDER : After performing each check and related adjustment, switch the power breaker OFF, then back ON again.

7-1. Circuit Boards

Board	Circuit	Check Points	Correct Voltage	Adjustment Point
CPU Board	Power source circuit	TP1-GND	DC12.8±0.1V	The VR at the side of the DC power source terminal block.
		TP2-GND	DC5.0±0.2V	None (replace when out of adjustment)
	Reset circuit	TP5-GND	DC5.0±0.2V	None (replace when out of adjustment)
		TP5-GND (Check with power breaker OFF)	less than DC5.0V	None (replace when out of adjustment)
	Power source circuit for temp. control.	TP15-GND	DC5.0±0.01V	VS3 on the CPU Board.
	Voltage Converter circuit (CH1)	TP12-GND	Table 1 value±0.07V	VS1 on the CPU Board. (DEV Temp. side)
	Voltage Converter circuit (CH2)	TP13-GND	Table 2 value±0.07V	VS2 on the CPU Board. (DRY Temp. side)

7-2. Sensors (Refer to CPU board in the above table)

CH1 : DEV Temp. Sensor (Table 1)

CH2 : DRY Temp. Sensor (Table 2)

Resistivity (KΩ)	Voltage (V)	Temperature Setting (°C)	Resistivity 2 (Ω)	Voltage (V)	Temperature Setting (°C)
3.3	3.05	36.1	510	0.10	6
3.6	2.69	33.5	560	0.57	34
3.9	2.44	31.7	620	1.13	68
4.3	2.06	29.0	680	1.71	103
4.7	1.72	26.6	750	2.40	144
5.1	1.43	24.5	820	3.10	186
5.6	1.08	22.0	910	4.00	240
6.2	0.72	19.4	1K	4.93	296

Speed of temperature rise:

DEV about 1.07°C/min

DRY about 80°C/min

NOTE : These values are under the condition that surrounding temp. is 20°C (68°F) until the FIX temp. gets to 28°C (82.4°F).

CHECKING CIRCUIT BOARDS, SENSORS AND ELECTRICAL LOADS

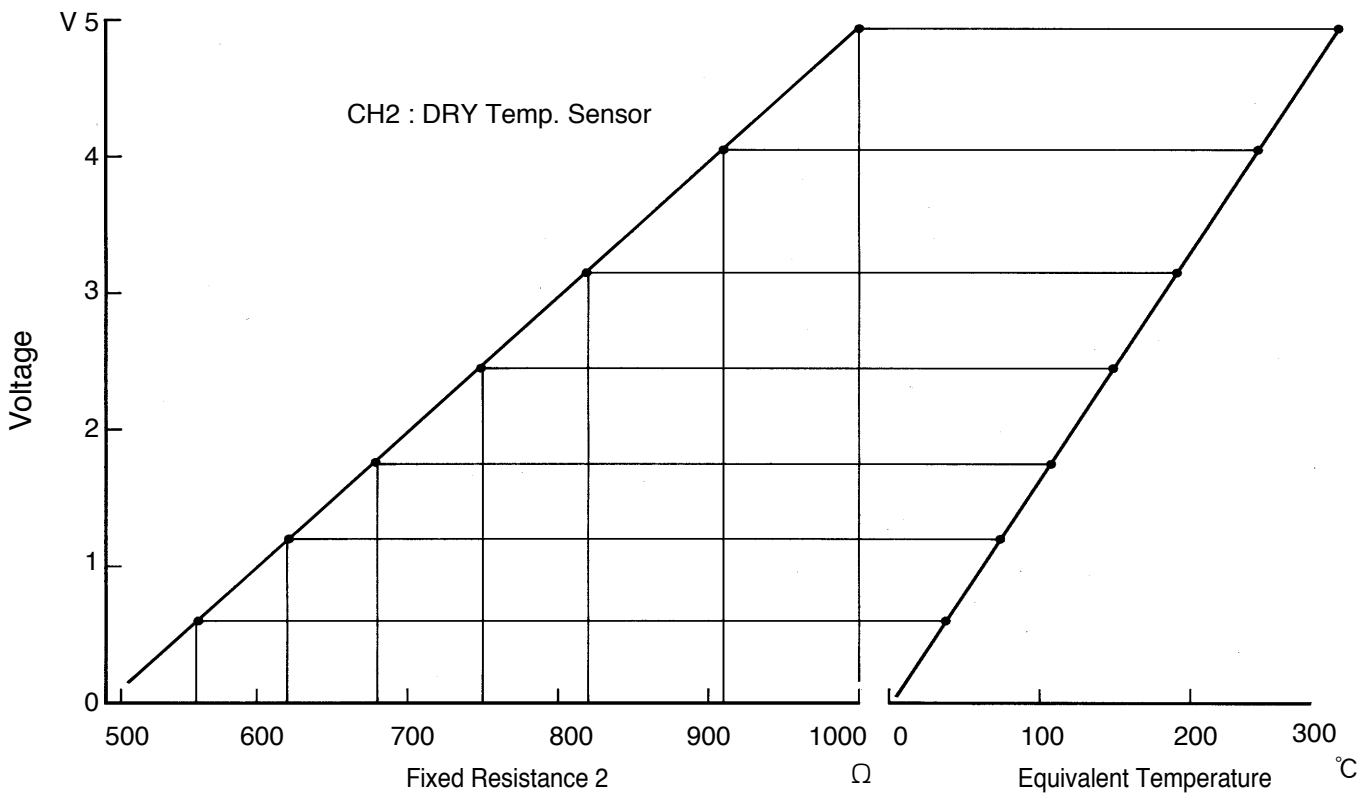
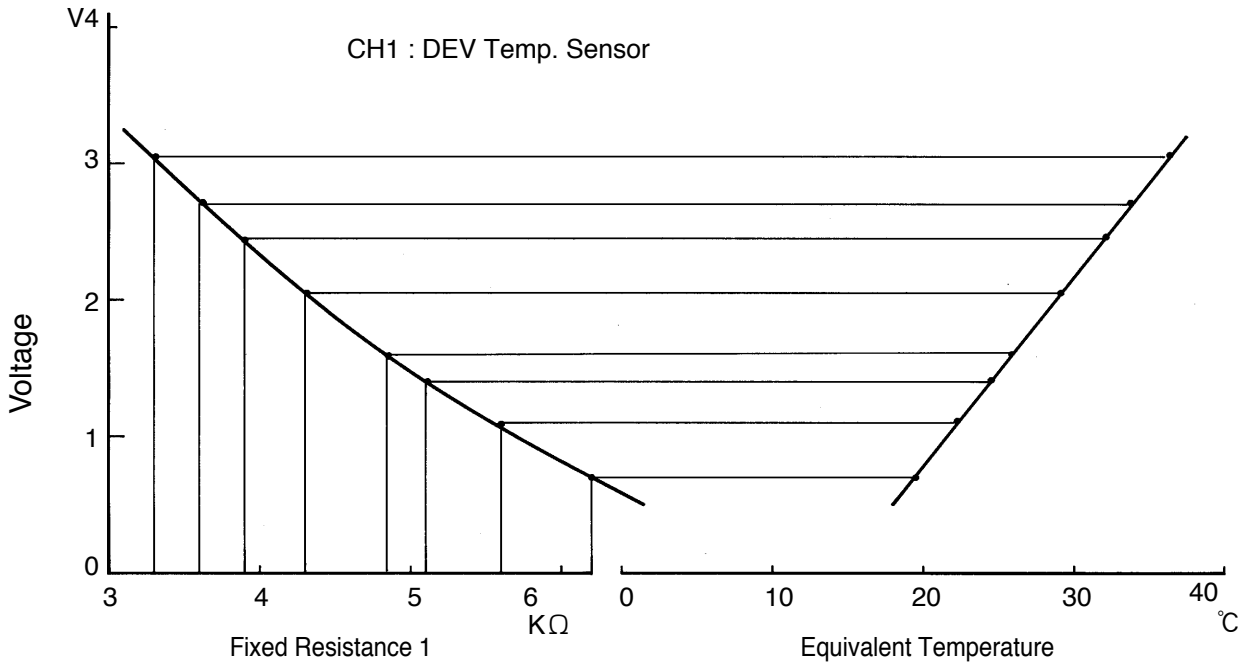
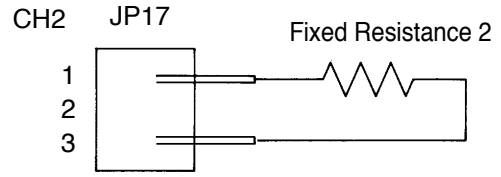
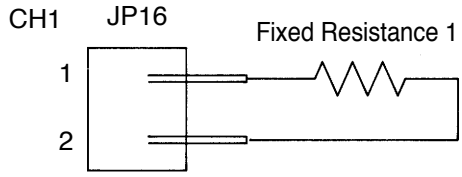

CHECKING CIRCUIT BOARDS, SENSORS AND ELECTRICAL LOADS

7-3. Load Outputs and Control Panel Inputs

- ① Make sure that the power breaker is OFF.
- ② Set Dip switch (DS1-1) on the CPU board to the ON position.
- ③ Select the desired processing cycle time by setting DIP switch (DS1-3,4) on the CPU board.
- ④ Make sure that connector JP2 from the Control Panel is connected properly to JJ2 on the CPU Board.
- ⑤ Switch the power breaker ON, then switch over to the maintenance mode.
- ⑥ Press and hold down th Replenish Button. Each of the loads will be indicated at 2 second intervals in the order shown in the following table. Release the switch to select the desired load.
- ⑦ Turn the RUN Button ON and OFF, and you can decide the load selected in the ⑥ to ON or OFF.

Order	Load	Check Point
1	READY Lamp	READY Lamp ON
2	RUN Lamp	RUN Lamp ON
3	DEV heater	CPU Board LED1 ON
4	DRY heater	CPU Board LED2 ON
5	Circulation pumps	CPU Board LED6 ON
6	DEV supply pump	CPU Board LED5 ON
7	FIX supply pump	CPU Board LED4 ON
8	Electromagnetic valve	CPU Board LED3 ON
9	Alarm (on CPU Board)	Alarm will sound
10	Drive motor (at processing)	Verify by sight
11	Drive motor (on standby)	Verify by sight
	Return to READY Lamp	

DS1-

No.3	No.4	Processing cycle time(Sec.)
OFF	OFF	90
ON	OFF	120
OFF	ON	180
ON	ON	Do not Use

7-4. Film Entry Sensor Input/Output

- ① Make sure the power breaker is OFF.
- ② Set all of the switches on DIP SW1 to OFF.
- ③ Make sure that connector JP3 from the film entry detection unit is connected to JJ3 on the CPU Board.
- ④ Switch the Power Breaker ON.
- ⑤ Use a sheet of film to activate one sensor at a time. After the sensor is activated remove the film and make sure that the alarm sounds after the time interval shown in the following table. Repeat this procedure for each sensor. (Refer to Page. 20 Time Chart.)

Cycle Time(sec.)	Alarm Timing(sec.)
90	after about 14.0
120	6.3
180	5.0

DEVELOPER TEMPERATURE CORRECTION

8. Developer Temperature Correction

Perform the following adjustment procedure whenever there is any difference between the value of the DEV Temp. Setting Volume on the temperature control board and the actual developer solution temperature in the developing tank.

- ① Make sure that the Power Breaker is OFF and set the DEV Temperature Setting Volume to 34°C.
- ② Switch the Power Breaker ON and press the RUN button.
- ③ Measure the voltage between TP15 and TP14 (GND) on the CPU Board. Turn the Standard Voltage Output Control Volume (VR5/VS3) on the temperature control board so that the voltage measures $5.0V \pm 0.01V$.
- ④ Wait for five minutes after the READY lamp comes ON and then measure the temperature of the solution in the developer tank.
- ⑤ Perform the following calculation, turn the DEV Temp Output Correction Volume (VR4/VS1) on the temperature control to adjust the voltage between TP12 and TP14 (GND) by the calculated result.

EXAMPLE :

When the temperature of the developer in the tank is 34.5°. The correction value is :

$$(34.5 - 34.0) \times 0.14 \text{ (fixed value)} = 0.07V$$

The voltage should therefore be increased by 0.07.

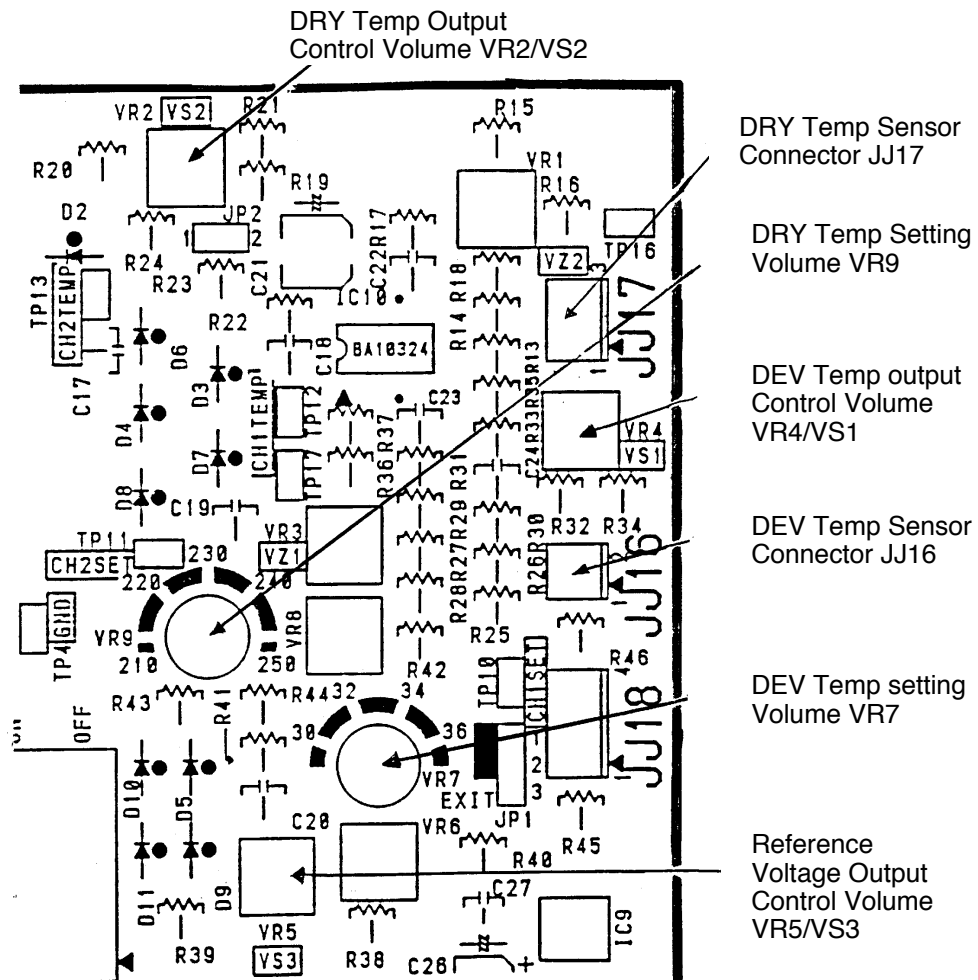

9. Electrical Components Diagram

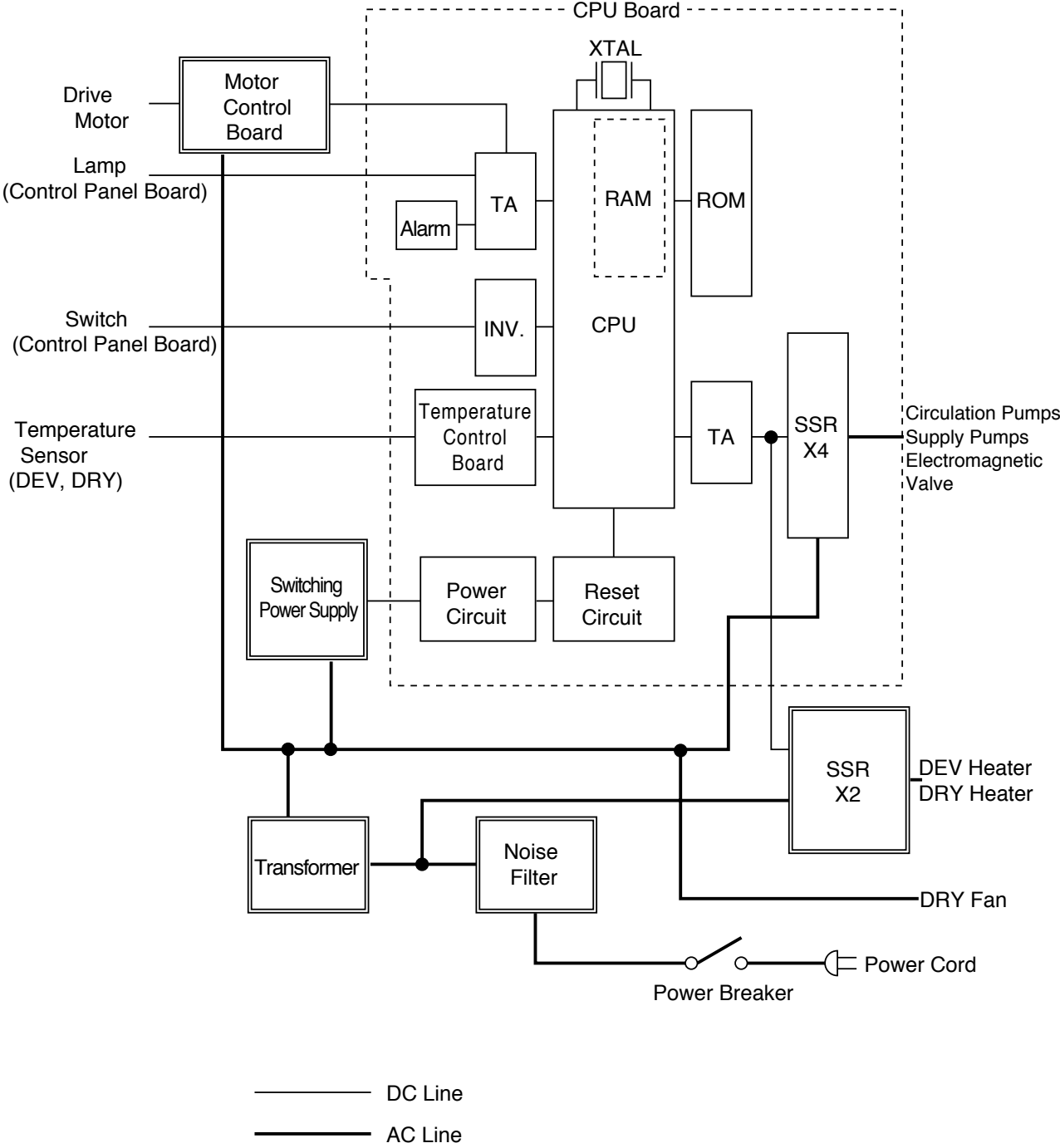

ELECTRICAL COMPONENTS DIAGRAM

9. Electrical Components Diagram

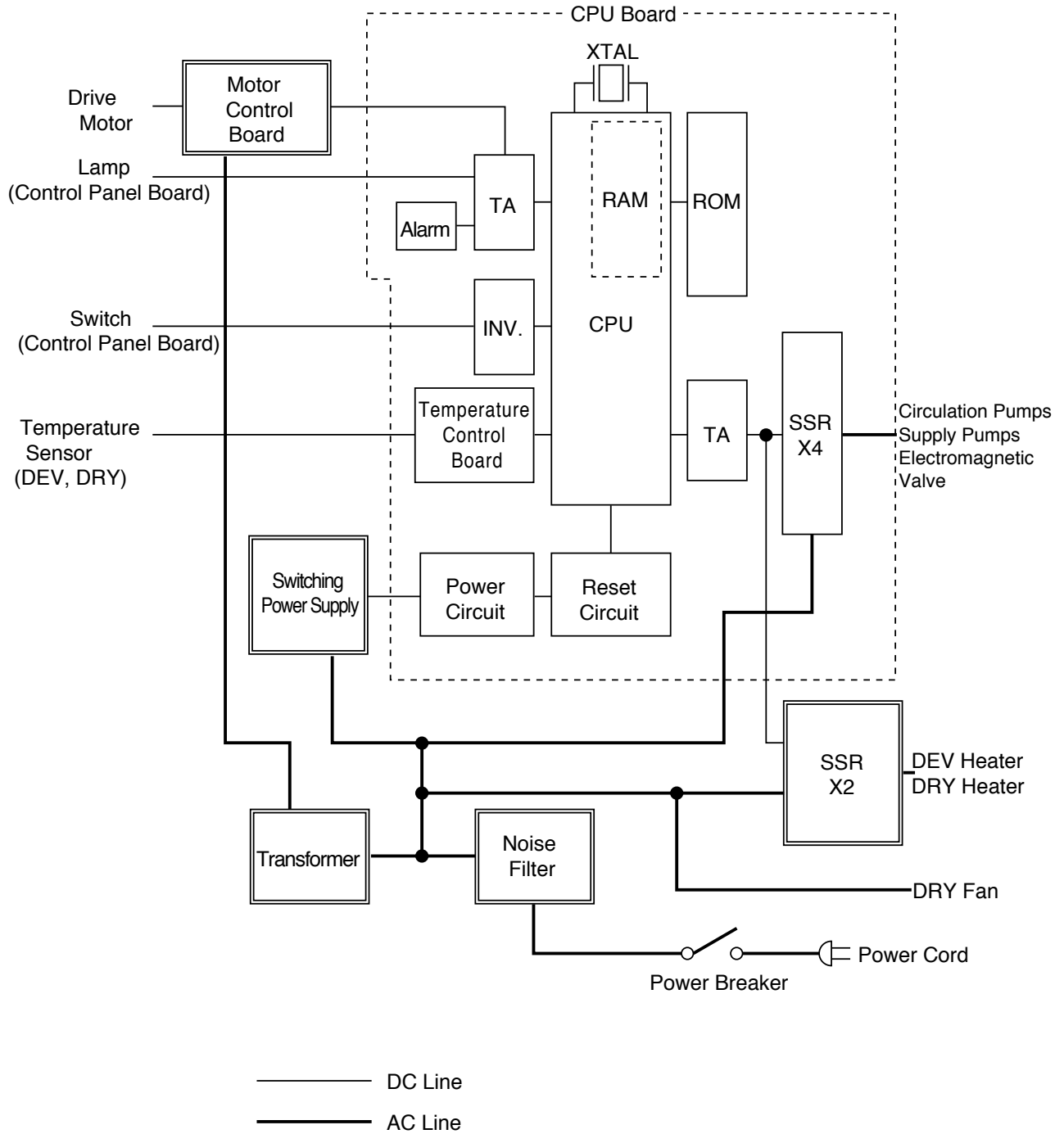

10. Wiring Diagram of Main Unit (CE)

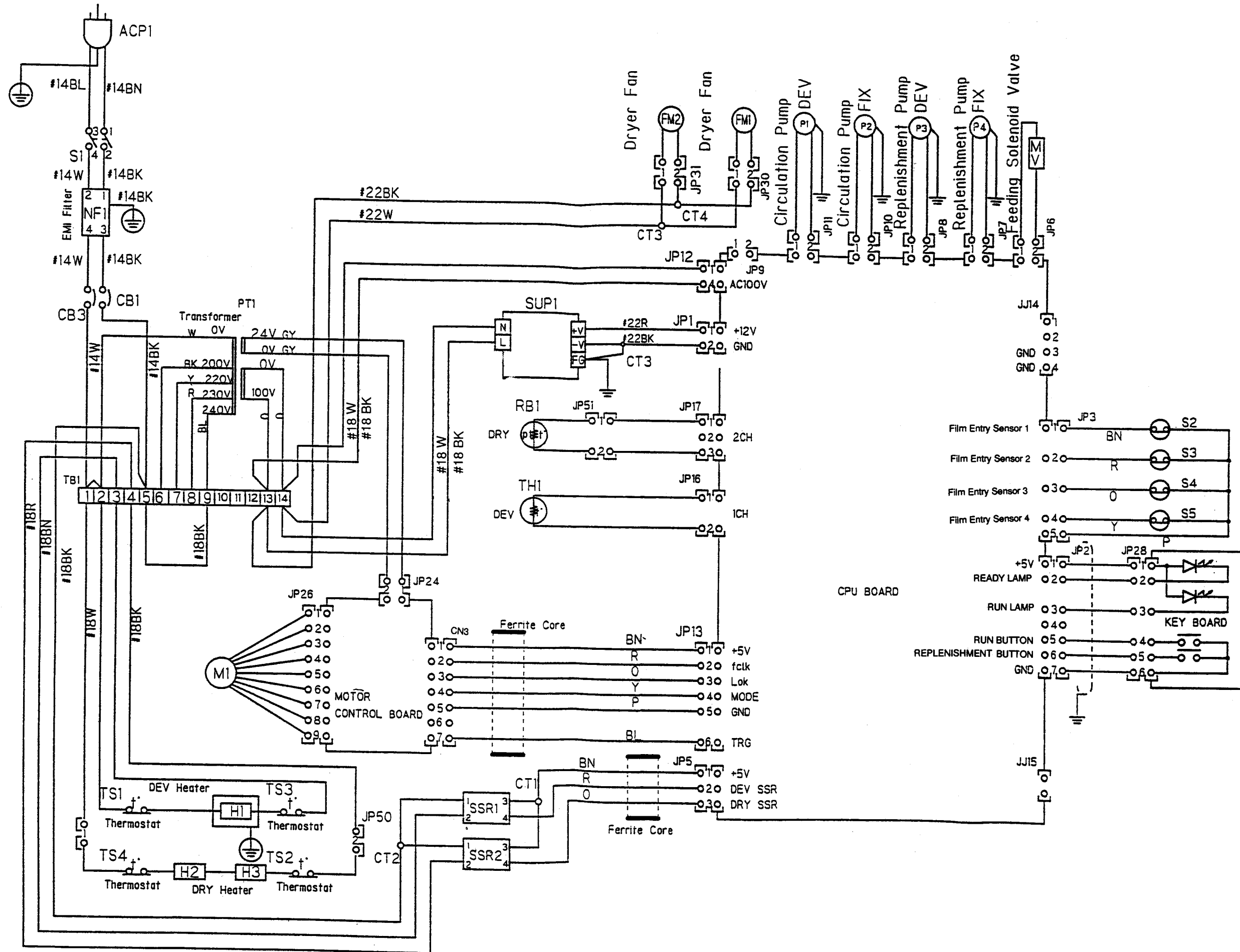

10. Wiring Diagram of Main Unit(UL)

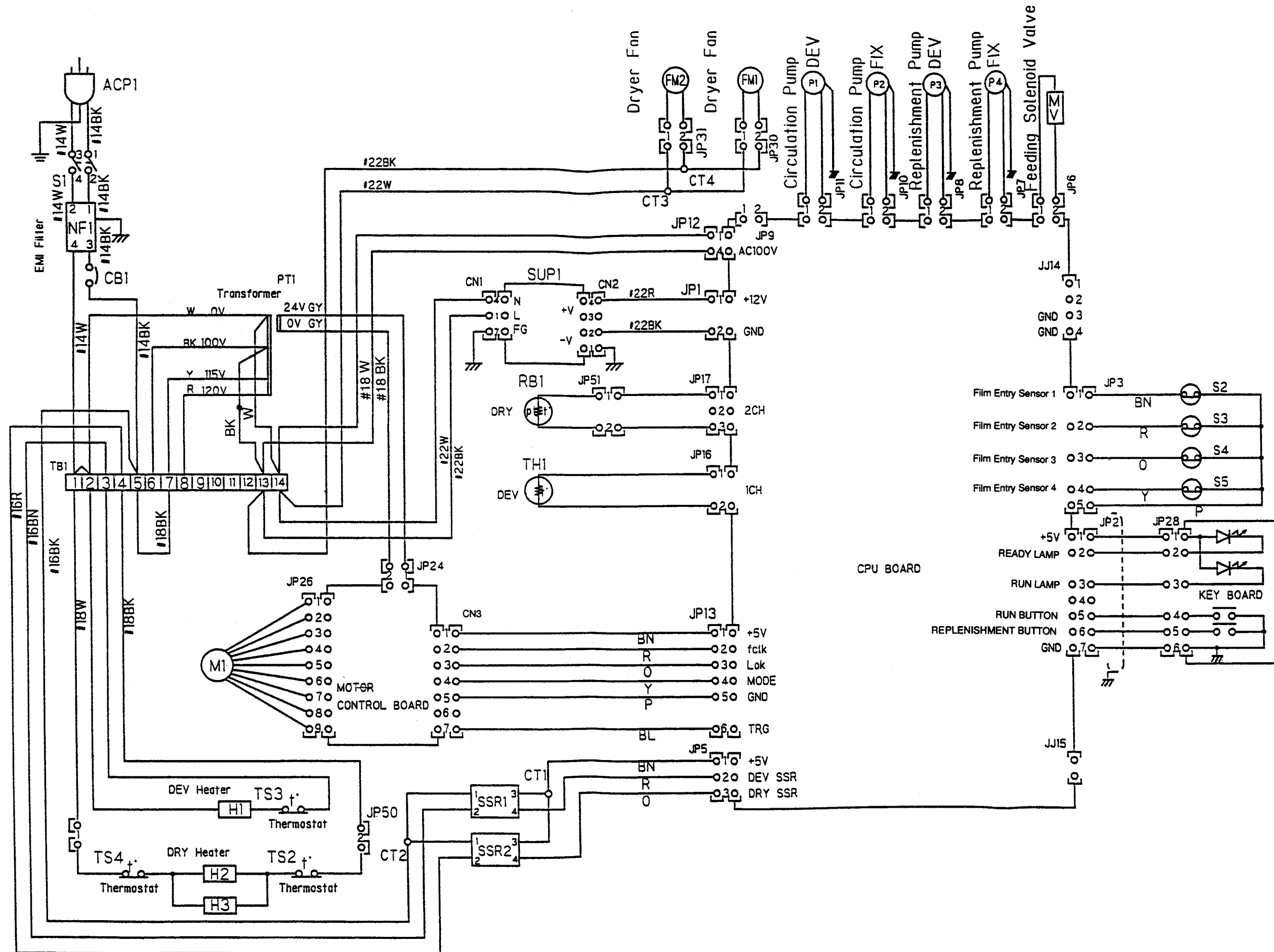

WIRING DIAGRAM OF MAIN UNIT

Main Body Electric Circuit Parts List

Symbol	Name	Manufacturer(UL/CE)	Model(UL/CE)	Remarks
S1	Switch	Matsushita	AJB201R	
S2~5	Reed switch	Japan Automation Co.	RS-9S	
	Reed switch magnet	Japan Automation Co.	RS-9M	
NF1	Noise filter	Nemic Ramda	MAF-1220-33	
TB1	Terminal block	Osada	OTB-525-14P-06-C	
CB1(CB3)	Circuit protector	AMF	W28XQ1A15	CB3: Only for CE
SSR1	SSR	Matsushita/JEL	SF12DPS-H1-4/S5C-215L-V	
SSR2	SSR	Matsushita/JEL	SF20DPS-H1-4/S5C-225L-V	
PT1	Transformer	KWAN-CHIU	WC-37Y/WC-38	
SUP1	Switching power supply	Nemic Ramda	VS15B-12/RWS15A-12	
M1	Drive motor	Kokusen Electric		
FM1, 2	DRY fan	Japan Servo Co.	CB55B4-Y	
MV	Electromagnetic valve	CKD	J248-676	
P1, 2	Magnet pump	Iwaki	MD-6-NL09	
P3, 4	Bellows pump	Iwaki	KBR-3XAU1M-S12	
H1	DEV heater	Shinnetsu Kogyo		
H2, 3	DRY heater unit	Asahi Glass		
TS2, 4	Overheat switch	Elmwood	8209-72-L140C	
TS3	Overheat switch	Elmwood	2455RBV-117-207	
JP1, 6~8, 10, 11, 24, 30, 31, 51	Connector	Molex	5557-02R	
JP2, 25	Connector	Molex	5102-07	
JP3	Connector	Molex	5102-05	
JP4, 20	Connector	Molex	5102-08	
JP5, 22	Connector	Molex	5102-03	
JP12, 50	Connector	Molex	5557-04R	
JP13	Connector	Molex	5102-06	
JP14	Connector	Molex	5102-04	
JP21	Connector	Molex	5102-02	
JP26	Connector	AMP	171822-9	
JP28	Connector	Molex	5102-06	
JJ30, 31	Connector	Molex	5559-02P	
ACP1	Power cord with plug	Kawasaki Densen	No.28495	(UL) L=2.81m
		Philips	57226604618	(CE) L=3.55m
	CPU board			Special parts
	Control Panel board			Special parts
	Motor control board			Special parts

11. Circuit Board Diagram

11-1. CPU Board

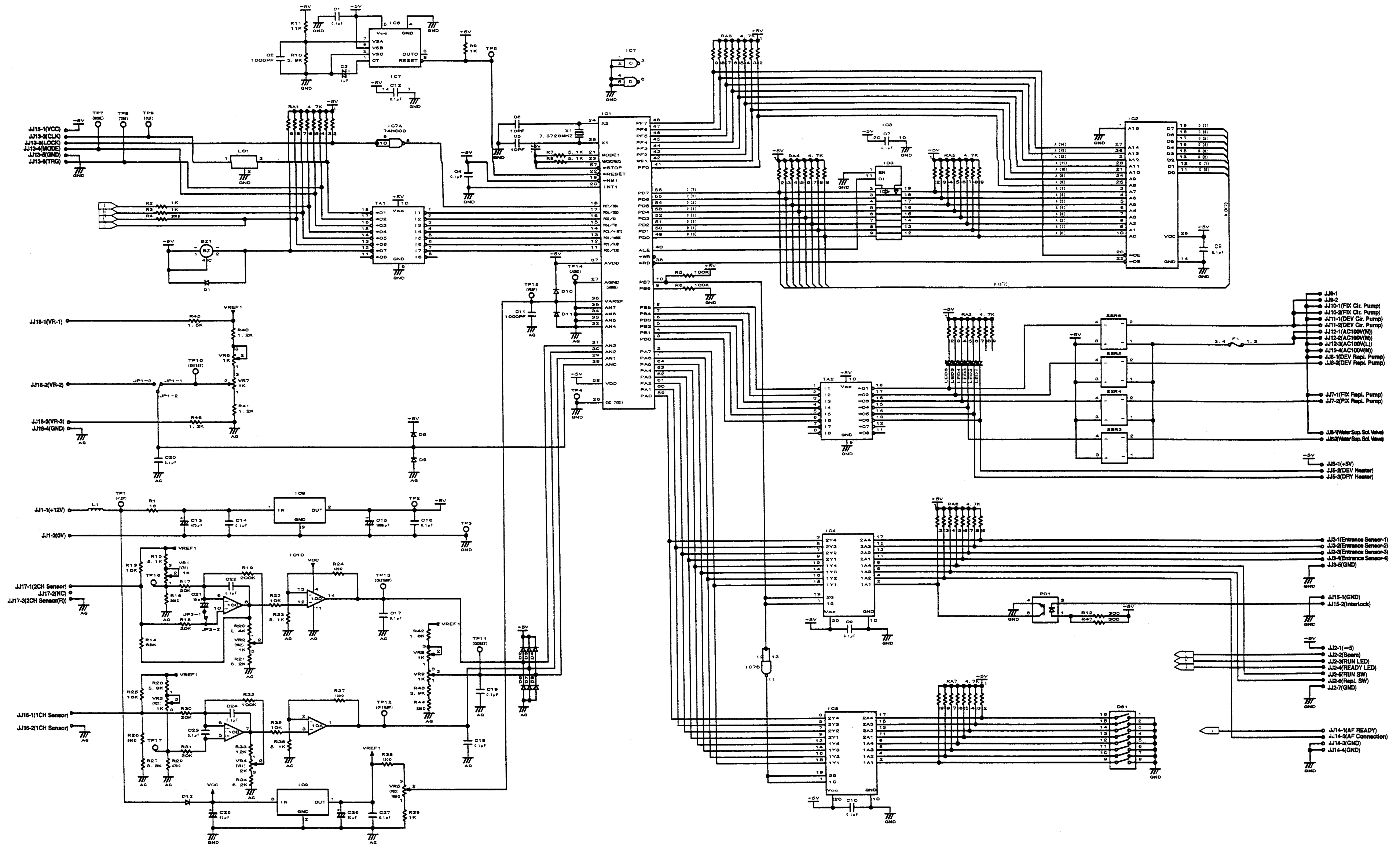

CIRCUIT BOARD DIAGRAM

CPU Board Parts Lists (1)

Symbol	Name	Manufacturer	Model	Remarks
IC1	CPU	NEC	μPD78C10AGF-3BE	
IC2	ROM	TI	TMS27C512-15	SRX-101A
IC3	TTL	Toshiba	TC74HC573AF	
IC4, IC5	TTL	Toshiba	TC74HC7240AF	
IC6	Power voltage IC	Fujitsu	MB3771PF-G-BND	
IC7	TTL	Toshiba	TC74HC00AF	
IC8	3 Point Regulator	Toshiba	TA7805S	
IC9	3 Point Regulator	Toshiba	TA78L06F	
IC10	Ope. amp.	Rohm	BA10324AF	TA75324F Toshiba
TA1, TA2	Sink screwdriver	Toshiba	TD62381FN	
LED1~6	LED	Toshiba	TLSU1002	Red
PC1	Photocoupler	Toshiba	TLP181GR	
D1~11	Shotkey Diode	Nippon Inter	EC10QS04	U1GWJ44 Toshiba
D12	Diode	Toshiba	UIBC44	
SSR3-6	Solid state relay	Matsushita	AQ80139-G01	TUV, UL, CSA
L1	Choking coil	Tokin Corporation	SN-8S-500	
RA1~7	Resistor array	Beckman	M9-1-4721	1/8W 4.7KΩ
R1	Tip Resistor	MICRON	MNS05N180JC	
R2, R3, R9, R39	Tip Resistor	Rohm	MCR18EZH102F	5W 18KΩ
R4	Tip Resistor	Rohm	MCR18EZH201J	1/8W 1KΩ F
R5,R6	Tip Resistor	Rohm	MCR18EZH104J	1/8W 200Ω
R7,R8	Tip Resistor	Rohm	MCR18EZH512J	1/8W 100KΩ
R10	Tip Resistor	KOA	RN73G2ATD392F	1/8W 5.1KΩ
R11	Tip Resistor	KOA	RN73G2ATD113F	1/10W 3.9KΩ F
R12, R16, R47	Tip Resistor	Rohm	MCR18EZH301F	1/10W 300KΩ F
R13, R22, R35	Tip Resistor	Rohm	MCR18EZH103F	1/8W 10Ω F
R14	Tip Resistor	Rohm	MCR18EZH683F	1/8W 68KΩ F
R15	Tip Resistor	Rohm	MCR18EZH512F	1/8W 5.1KΩ F
R17, R18, R30, R31	Tip Resistor	Rohm	MCR18EZH203F	1/8W 20KΩ F
R19	Tip Resistor	Rohm	MCR18EZH204F	1/8W 200KΩ F
R20	Tip Resistor	Rohm	MCR18EZH242F	1/8W 2.4KΩ F
R21	Tip Resistor	Rohm	MCR18EZH822F	1/8W 8.2KΩ F
R23, R36	Tip Resistor	Rohm	MCR18EZH512F	1/8W 5.1KΩ F
R25	Tip Resistor	Rohm	MCR18EZH163F	1/8W 16KΩ F
R26	Tip Resistor	Rohm	MCR18EZH561F	1/8W 560KΩ F
R27, R28	Tip Resistor	Rohm	MCR18EZH332F	1/8W 3.3KΩ F
R29	Tip Resistor	Rohm	MCR18EZH471F	1/8W 470KΩ F
R33	Tip Resistor	Rohm	MCR18EZH123F	1/8W 12KΩ F
R34	Tip Resistor	Rohm	MCR18EZH622J	1/8W 6.2KΩ
R41, R46	Tip Resistor	Rohm	MCR18EZH122F	1/8W 1.2KΩ F
R40	Tip Resistor	Rohm	MCR18EZH122J	1/8W 1.2KΩ
R42	Tip Resistor	Rohm	MCR18EZH162J	1/8W 1.6KΩ
R45	Tip Resistor	Rohm	MCR18EZH152J	1/8W 1.5KΩ
R43	Tip Resistor	Rohm	MCR18EZH392F	1/8W 3.9KΩ F
R44	Tip Resistor	Rohm	MCR18EZH221F	1/8W 220KΩ F

CIRCUIT BOARD DIAGRAM

CPU Board Parts Lists (2)

Symbol	Name	Manufacturer	Model	Remarks
R32	Tip Resistor	Rohm	MCR18EZH104F	1/8W 100Ω F
R38	Tip Resistor	Rohm	MCR18EZH121F	1/8W 120Ω F
R24, R37	Tip Resistor	Rohm	MCR18EZH101F	1/8W 100Ω F
C17, C18, C19, C20, C22, C23, C24	Ceramic tip capacitor	Murata	GRM42-6R104K50	0.1μF/50V
C2, C11	Ceramic tip capacitor	Murata	GRM40CH102J50	1000pF/50V
C5, C6	Ceramic tip capacitor	Murata	GRM40CH100D50	10pF/50V
C3	Tantale capacitor	NEC	MSVA1E105M	1μF/25V
C15	Electrolytic capacitor	Nippon chemicon	KME25VB-1000M	1000μF/25V
C13	Electrolytic capacitor	Nippon chemicon	KME25VB-470M	470μF/25V
C1, C4, C7-10, C12, C14, C16, C27	Ceramic tip capacitor	Murata	GRM40F104Z50	0.1μF/50V Pascon
C21	Both type electrolytic	Nippon chemicon	MVK35VC10MBPF60	10μF/35V
C25	Electrolytic capacitor	Nippon chemicon	MVK25VC47MH63	47μF/25V
C26	Electrolytic capacitor	Nippon chemicon	MVK35VC10ME55	10μF/35V
LC1	Emifil	Murata	DSS306-55B271M100	
VR1~3, VR6, VR8	Thermet trimmer	Kopal	CT-6P102J	1KΩ
VR7, VR9	Thermet trimmer	Kopal	RJ-6P102J	1KΩ Round shape
VR4	Thermet trimmer	Kopal	CT-6P202J	2KΩ
VR5	Thermet trimmer	Kopal	CT-6P101J	100KΩ
X1	Crystal	Kaneishi	HC-49/U-S7.3728MHz	
BZ1	Buzzer	Star Mfg.	KMB-06	
DS1	DIP Switch	OMRON	A6B8101	
(IC2)	IC Socket	Matsushita	AXS102813	28pin(For ROM)
TO1~5, TO7~17	Check Terminal	Mac Eight	HK-2-G	For check TO6luck
F1	Fuse	Ritel	2183. 15	
FH1	Fuse holder	Nagasawa Electric	FP-217	
(IC9)	Heat sink	Ryosan	0SH-2425-SP25	For TA7805S
JJ1, JJ6~11	Connector	Molex	5566-02A	JJ9 isn't contained.
JJ2	Connector	Molex	5045-07A	
JJ3	Connector	Molex	5045-05A	
JJ5, JJ17	Connector	Molex	5045-03A	
JJ12	Connector	Molex	5566-04A	
JJ13	Connector	Molex	5045-06A	
JJ14, JJ18	Connector	Molex	5045-04A	
JJ15, JJ16	Connector	Molex	5045-02A	JJ15 isn't contained.
JP1	Rapping terminal	Mac Eight	WL-1	connected to 34pin.
JP2	Rapping terminal	Mac Eight	WL-1	connected to 34 pin
JPP1, JPP2	Jaump socket	Mac Eight	JS-1	
	Silicon rubbar	Shinetsu	TC-30BG	For T0-220 TA7805S
	M3 Screw			For TA7805S
	Print Board	Sougou circuit		

CPU Board Parts Layout

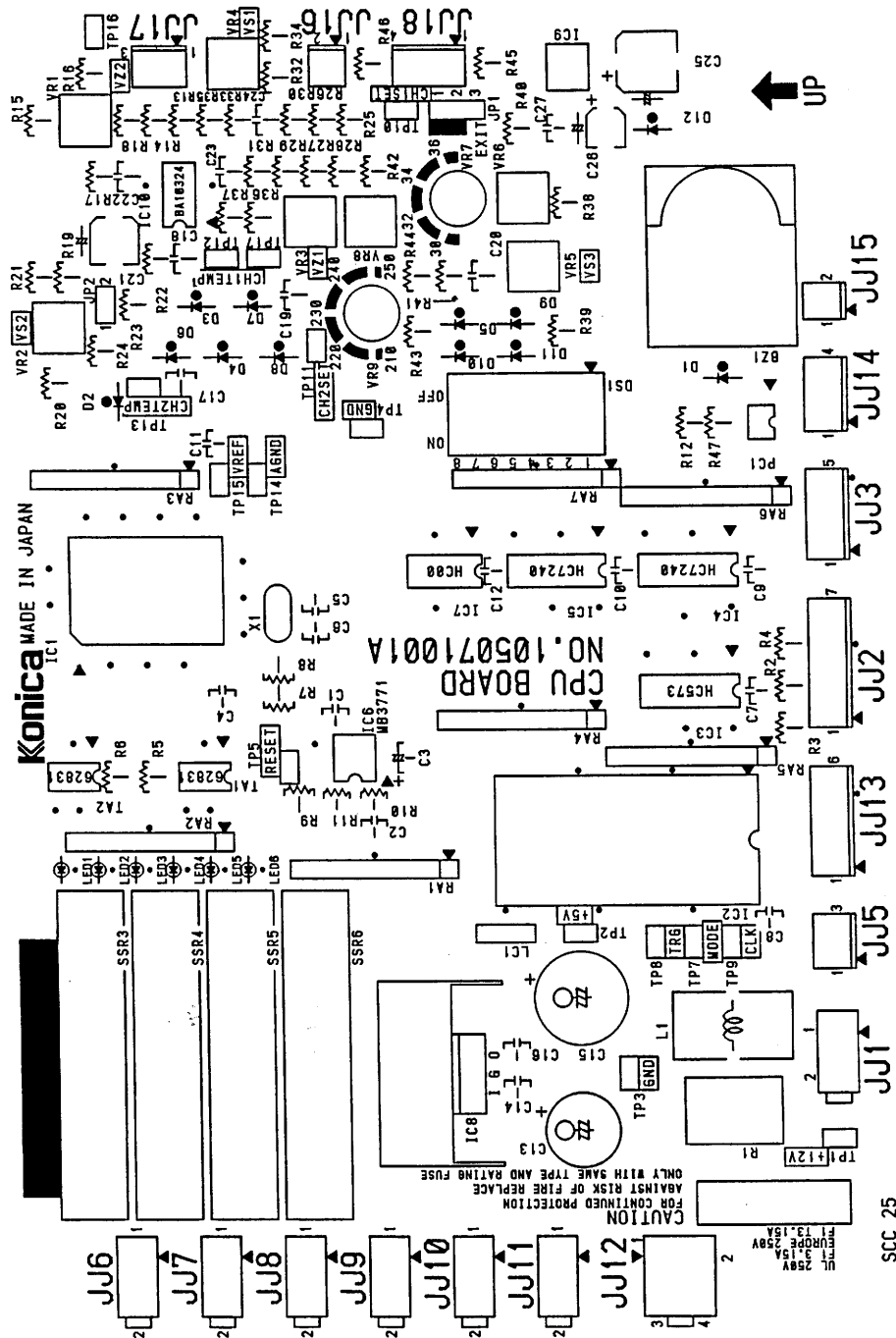

SCC 25

CIRCUIT BOARD DIAGRAM

11-2. Control Panel Board Circuit Diagram

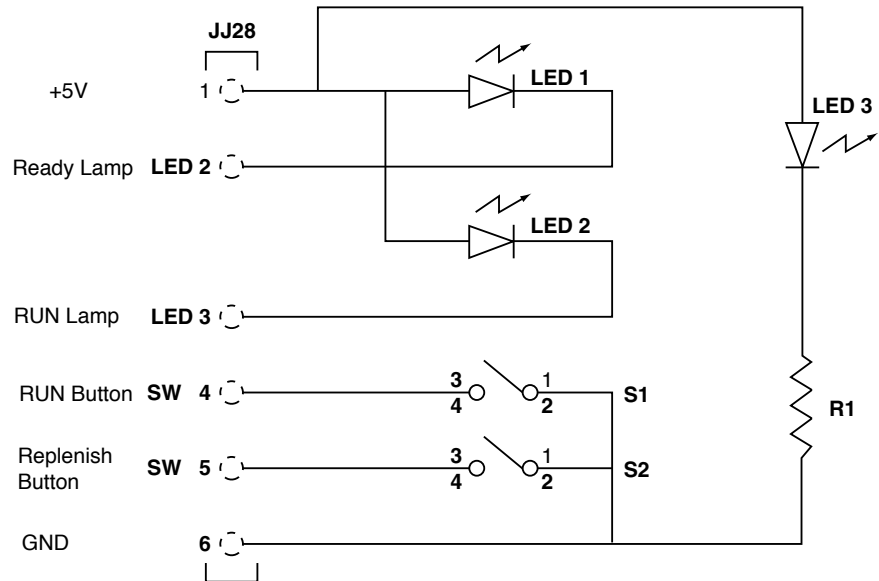

KEY Board Parts List

Symbol	Name	Manufacturer	Model	Remarks
S1, 2	Switch	Fuji Electric	AB12-EA137	
S1, S2	Push Button	Fuji Electric	ABX112-H	
LED1, 2	LED	Toshiba	TLR218P	
LED3	LED	Stanley Electric	MPR3338S	
R1	Resistor	Matsushita	ERD-25TJ202	2k Ω /1/4W
JJ28	Connector	Molex	5045-06A	
Print Board				Special part

KEY Board Parts Diagram

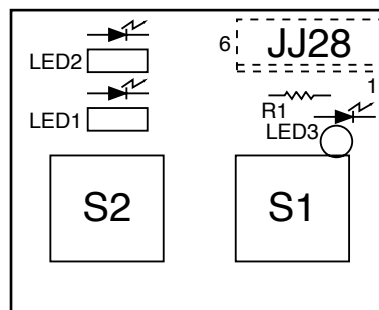

11-3. Motor Control Board

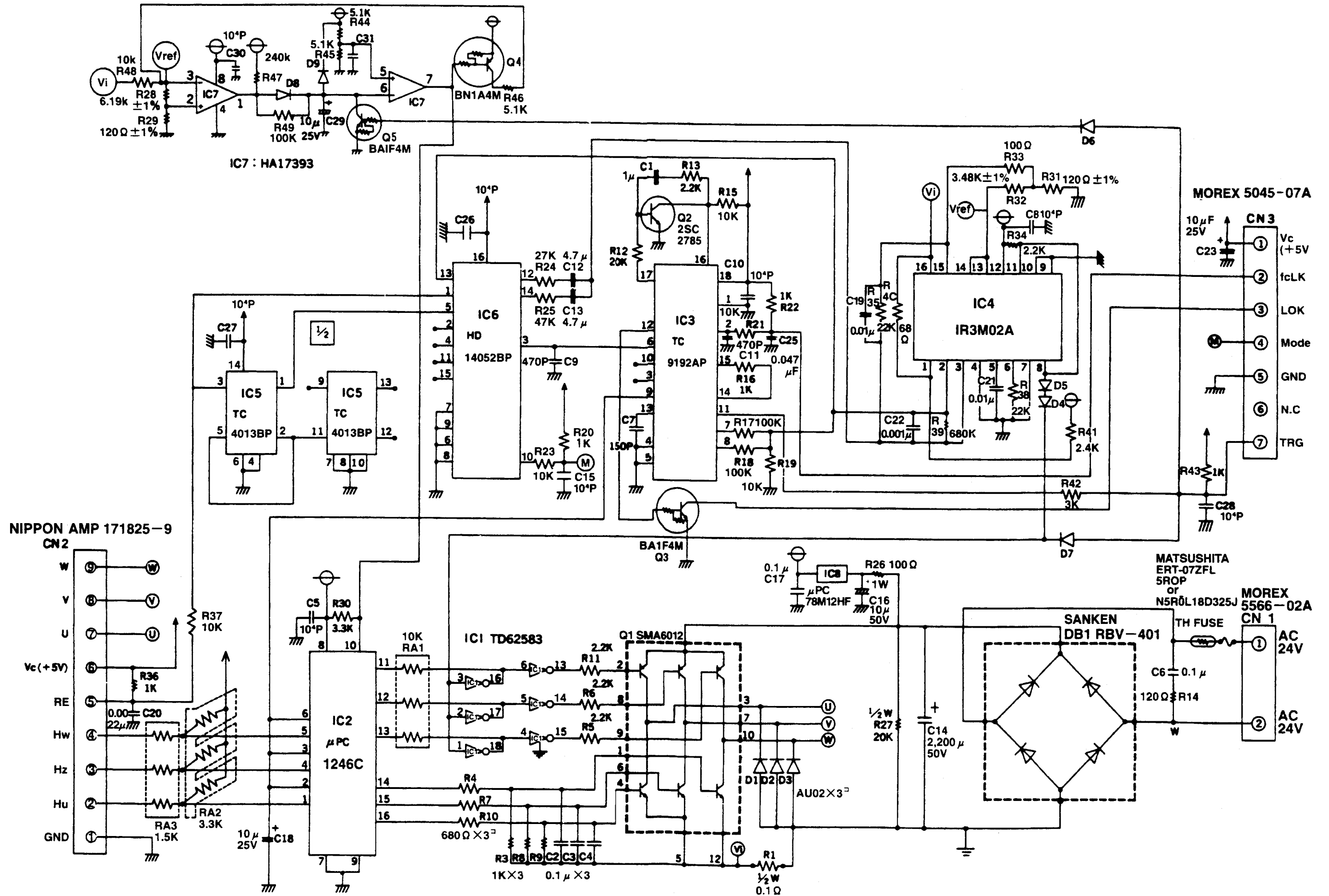

CIRCUIT BOARD DIAGRAM

Motor Control Board Parts List (1)

Symbol	Name	Manufacturer	Model	Remarks
IC1	IC	Toshiba	TD62583AP	
IC2	IC	NEC	μ PC1246C	
IC3	IC	Toshiba	TC9192AP or Toshiba TC9192P	
IC4	IC	Sharp	IR3M02A	
		NEC	μ PC494C	
IC5	IC	Toshiba	TC4013BP or Motroller MC14013BCP	
IC6	IC	Hitachi	HD14052BP	
		NEC	μ PD4052BP	
		Toshiba	TC4052BP	
IC7	IC	Hitachi	HA17393	
		NEC	μ PC393C	
IC8	IC	NEC	μ PC78M12AHF or NEC μ PC78M12HF	
Q1	Transistor Array	Sanken	SMA6012 or Sanken SLA6012	
Q2	Transistor	NEC	2SC2785	
Q3, 5	Transistor	NEC	BA1F4M	
		Rohm	DTC124	
Q4	Transistor	NEC	BN1A4M	
D1~3	Diode	Sanken	AU02V1	
		Sanken	AU02V0	
		Hitachi	DFA1A2	
D4~9	Diode	Hitachi	1S2076A	
		NEC	1S953	
DB1	Diode array	Sanken	RBV-401	
RA1	Resistor array	Matsushita	EXB-F6V103J(Y)	
		KOA	RKCB3S103J	
		Rohm	RMHA3-103J	
RA2	Resistor array	Matsushita	EXB-F4E332J(Y)	
		KOA	RKCB3332J	
		Rohm	RMLS3-332J	
RA3	Resistor array	Matsushita	EXB-F6V152J(Y)	
		KOA	RKCB3S152J	
		Rohm	RMHA3-152J	
C1	Condenser	Nichicon	UEB1H010MAA	1 μ F / \pm 50V
		Nichicon	UVP1H010MAA	
		Nippon Chemi-con	SME50VB1BP	
C2~4, 17	Condenser	NEC	TPD33Y5V1E104ZL-W	0.1 μ F / 25V
		NEC	D33Y5V1EN104Z-51	
C5, 8, 10, 15, 26-28, 30, 31	Condenser	Matsushita	ECK-PH1032ZF	10.000pF / 50V
C6	Condenser	Nissei Electric	MMTV104J50	0.1 μ F / 50V
		Nichicon	QYA1H104K	
C7	Condenser	Matsushita	ECC-R1H151JC4	150pF / 50V
C9, 11	Condenser	Matsushita	ECK-R1H471KB	470pF / 50V
C12, 13	Condenser	Nichicon	UEB1E4R7MAA	4.7 μ F / \pm 25V
		Nichicon	UVP1E4R7MAA	

CIRCUIT BOARD DIAGRAM

Motor Control Board Parts List (2)

Symbol	Name	Manufacturer	Model	Remarks
C14	Condenser	Matsushita	ECES1HU222EG	2,200 μ F / 50V
		Nichicon	LLK1H222MHSZ	
C16	Condenser	Nichicon	UVZ1H100MAH	10 μ F / 50V
		Nichicon	UPC-1H100MA1HS	
C18, 23, 29	Condenser	Nichicon	ULB1E100MAA	10 μ F / 25V
		Nichicon	UVX1E100MAA	
		Nippon Chemi-con	SME25VB10	
C19, 21	Condenser	Nissei Electric	AMZV103K50	0.01 μ F / 50V
		Nichicon	QYA1H103K	
		Nichicon	QYX1H103K	
C20	Condenser	Nissei Electric	AMZV222K50	0.0022 μ F / 50V
		Nichicon	QYA1H222K	
		Nichicon	QYX1H222K	
C22	Condenser	Nissei Electric	AMZV102K50	0.001 μ F / 50V
		Nichicon	QYA1H102K	
		Nichicon	QYX1H102K	
C25	Condenser	Nissei Electric	AMZV473K50	0.047 μ F / 50V
		Nichicon	QYA1H473K	
TH	Thermistor	Oizumi	N5R0L18D325J or Matsushita ERT-D7ZFL5R0P	
R1	Resistor	Matsushita	ERX-12-SJR20	0.2 Ω / 1/2W
		Rohm	CRH50JXR20	
R3, 8, 9, 16, 20, 22, 36, 43	Resistor	Matsushita	ERD-S2-TJ102	1k Ω / 1/4W
		Matsushita	ERD25VJ102	
R4, 7, 10	Resistor	Matsushita	ERD-S2-TJ681	680 Ω / 1/4W
		Matsushita	ERD25VJ681	
R5, 6, 11, 13, 34	Resistor	Matsushita	ERD-S2-TJ222	2.2k Ω / 1/4W
		Matsushita	ERD25VJ222	
R12	Resistor	Matsushita	ERD-S2-TJ203	20k Ω / 1/4W
		Matsushita	ERD25VJ203	
R14	Resistor	Matsushita	ERG-1-SJ121V	120 Ω / 1W
R15, 19, 21, 23, 37	Resistor	Matsushita	ERD-S2-TJ103	10k Ω / 1/4W
		Matsushita	ERD25VJ103	
R17, 18, 49	Resistor	Matsushita	ERD-S2-TJ104	100 Ω / 1/4W
		Matsushita	ERD25VJ104	
R24	Resistor	Matsushita	ERD-S2-TJ273	27k Ω / 1/4W
R25	Resistor	Matsushita	ERD-S2-TJ473	47 Ω / 1/4W
		Matsushita	ERD25VJ473	
R26	Resistor	Matsushita	ERG-1-SJ101V	100 Ω / 1W
R27	Resistor	Matsushita	ERD50TJ203	20k Ω / 1/2W
		Rohm	R50XJ20K Ω	
R28	Resistor	Matsushita	ERO-S2-CKF6191	6.19k Ω \pm 1% / 1/4W
R30	Resistor	Matsushita	ERD-S2-TJ332	3.3k Ω / 1/4W
		Matsushita	ERD25VJ332	
R31, 29	Resistor	Matsushita	ERO-S2-CKF1200	3.48k Ω \pm 1% / 1/4W
R32	Resistor	Matsushita	ERO-S2-CKF3481	100 Ω / 1/4W

Motor Control Board Parts List (3)

Symbol	Name	Manufacturer	Model	Remarks
R33	Resistor	Matsushita	ERD-S2-TJ101	100Ω / 1/4W
		Matsushita	ERD25VJ101	
R35, 38	Resistor	Matsushita	ERD-S2-TJ223	22kΩ / 1/4W
		Matsushita	ERD25VJ223	
R39	Resistor	Matsushita	ERD-S2-TJ684	680kΩ / 1/4W
		Matsushita	ERD25VJ684	
R40	Resistor	Matsushita	ERD-S2-TJ680	68Ω / 1/4W
		Matsushita	ERD25VJ680	
R41	Resistor	Matsushita	ERD-S2-TJ242	2.4kΩ / 1/4W
		Matsushita	ERD25VJ242	
R42	Resistor	Matsushita	ERD-S2-TJ302	3kΩ / 1/4W
		Matsushita	ERD25VJ302	
R44~46	Resistor	Matsushita	ERD-S2-TJ512	5.1kΩ / 1/4W
		Matsushita	ERD25VJ512	
R47	Resistor	Matsushita	ERD-S2-TJ244	240kΩ / 1/4W
		Matsushita	ERD25VJ244	
F1	Fuse	RITEL	21802.5	250V, 2.5A
F1	Fuse Holder	Emuden Musen	H-0452	
CN1	Connector	Molex	5566-02A	
CN2	Connector	AMP	171825-9	
CN3	Connector	Molex	5045-07A	
	Print board			

PRE-INSTALLATION INSTRUCTIONS

12. Pre-Installation Instructions

12-1. Packaging

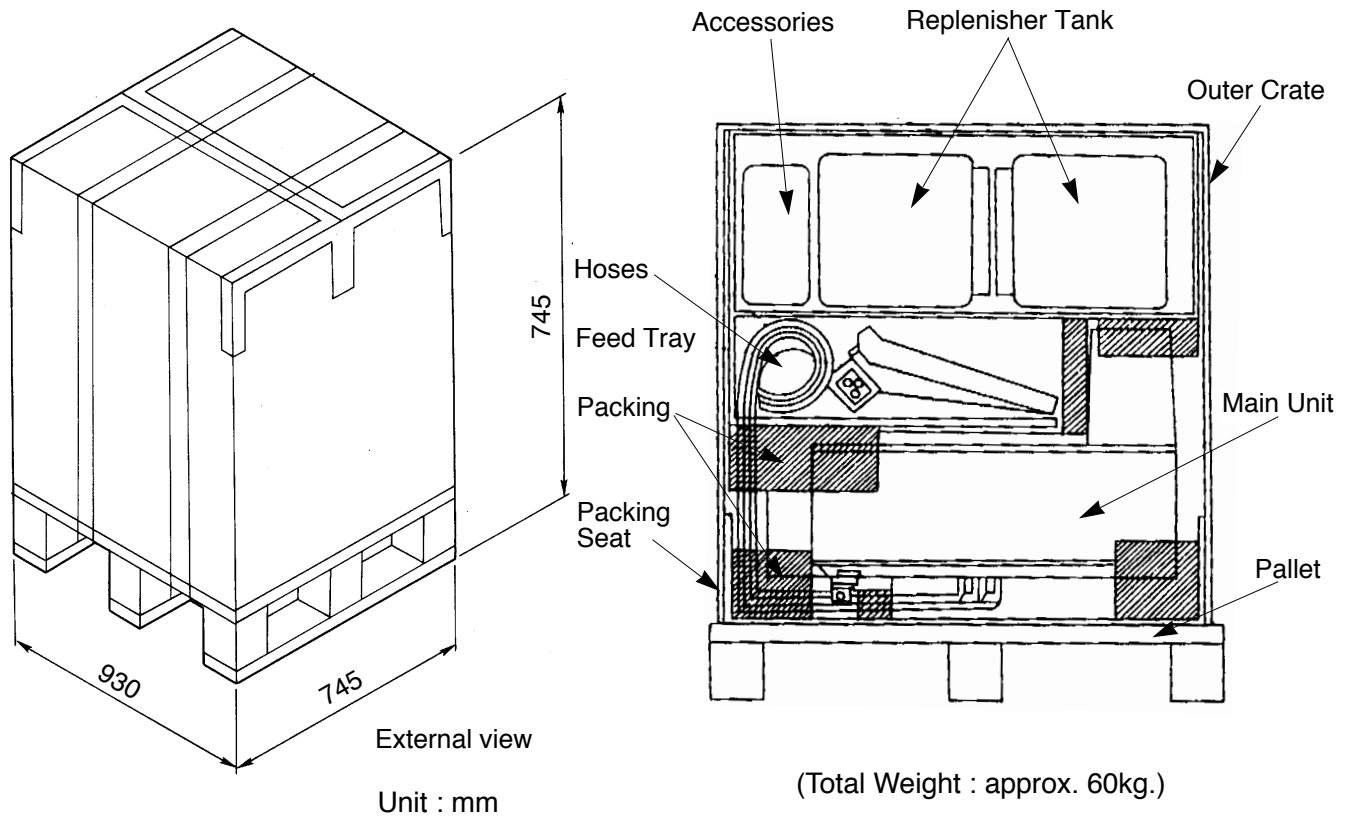

12-2. Contents

Label	Contents	Quantity	Remarks
X-RAY FILM PROCESSING SRX-101A	SRX-101A Main Unit	1	
	Feed Tray	1	
	25 l Replenisher Tank	1	
	Accessories	1	
	Operation Manual	1	
	Certification of inspection	1	

12-3. Package Contents Verification

Before installing the SRX-101A, make sure to check the main unit and accessory equipment for any missing parts or damage during transportation.

- (1) Check to see if the model name and numbers printed on the outside of the package correspond to what the customer ordered.
- (2) Check if there is any extraordinary damage to the outside of the package.
- (3) Open the package while following the precautions outline in the next section.
- (4) Check if there is any missing parts by matching the contents of the package with the packing list provided.
- (5) Check all the parts for any external damage.

NOTE :

If there are any missing parts or damage, notify your local KONICA representative immediately.

12-4. Precautions to Take When Opening the Package

- (1) At least two persons are needed to hand-carry the SRX-101A.
- (2) Be careful when cutting the bands away from the package. They have been bound tightly and could cause injury when released.
- (3) The racks have been wrapped in plastic sheets.
There is cushioning material between the racks and processing tanks.
Remove carefully and dispose of all these materials before beginning installation.

12-5. Opening the Package

- (1) Use scissors to cut the bands.
- (2) Cut the top of the outer crate open with a utility knife.
- (3) Lift the box of accessories up and out over the top of the crate. This package contains the replenisher tank and other accessories.
- (4) Lift the outer crate up and over the main unit.
- (5) Remove the Feed Tray.
- (6) Unload the Main Unit from the pallet.

At least two persons are necessary to lift and transport the processor.

PRE-INSTALLATION INSTRUCTIONS

25 ℓ Replenisher Tank

ID. NO.	Parts Name	Qty	Remarks
1	Hose band	2	Tyton. SNP-12-HSO
2	Replenisher pipe (DEV)	1	
3	Replenisher pipe (FIX)	1	
4	Replenisher filter	2	
5	Filter cap	2	
6	Name plate(DEV)	2	
7	Stirring rod(DEV)	1	(yellow)
8	Floating lid	2	
9	Clamp	2	Kitagawa Industrial Co. LTD. CKS-16-H
10	Name plate(FIX)	2	
11	Replenisher tank	2	
12	Stirring rod (FIX)	1	(red)

25 ℓ Replenisher Tank

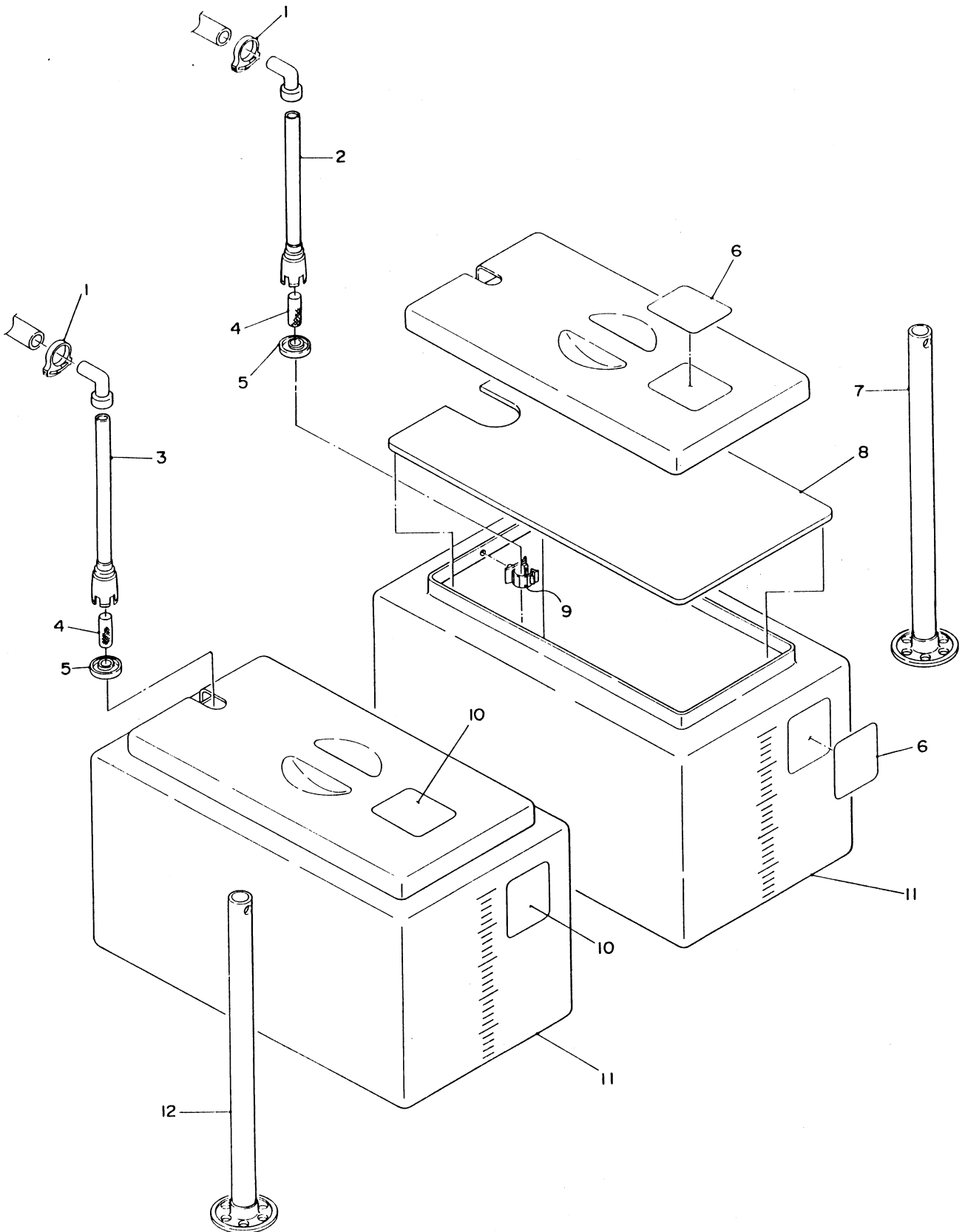

PRE-INSTALLATION INSTRUCTIONS

Set of Accessories

ID.No.	Parts Name	Qty
1	Gear	1
2	Idler gear	1
3	Gear	1
4	Idler gear	1
5	Stopper	1
6	Shaft support	1
7	Coil spring	2
8	Coil spring	2
9	Rubber pad	4
10	Bushing	1
11	Packing	1
12	Funnel	1
13	Plastic beaker(Measuring cup)	1

Accessories

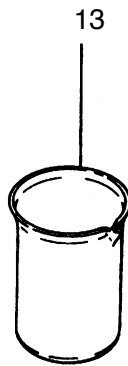
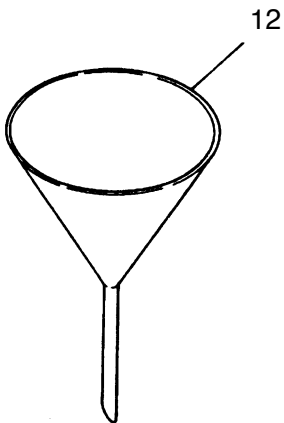
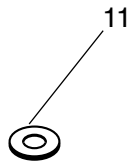
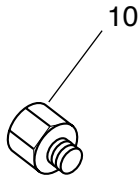
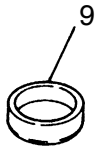
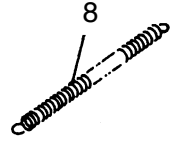
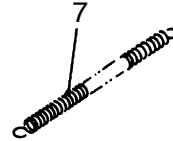
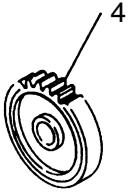
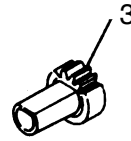

INSTALLATION INSTRUCTIONS AND PRECAUTIONS

13. Installation Instructions and Precautions

13-1. Space Requirements

The accompanying diagram shows the minimum space required to operate, maintain and repair the SRX-101A. Any space smaller than these dimensions will result in longer shutdown times during maintenance and repair.

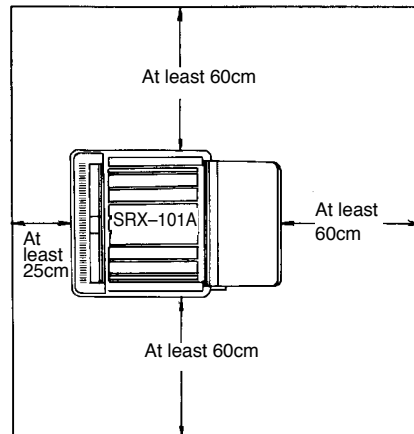

13-2. Setting the Main Unit in place (Refer to the Diagram Below)

- ① Place the Main Unit on the Stand (Option), a desk or a work bench so that the supply and drainage valves are easily accessible.
- ② The SRX-101A, when filled with processing solutions, weighs approximately 47 kg. Make sure that the support to be used is more than capable of bearing this weight and also resistant to the corrosive effects of the developer (PH 11) and fixer (PH 4) chemicals.
- ③ Do not install the processor in high vibration areas or where it cannot be properly leveled.
- ④ Place the SRX-101A at a height from the floor that fulfills both of the following conditions.
 - a. The liquid surface inside the replenisher tank is below the full marks of the main unit processing tanks.
 - b. The top of the main unit support is less than 130cm from the floor or other surface where the replenish tank is standing.

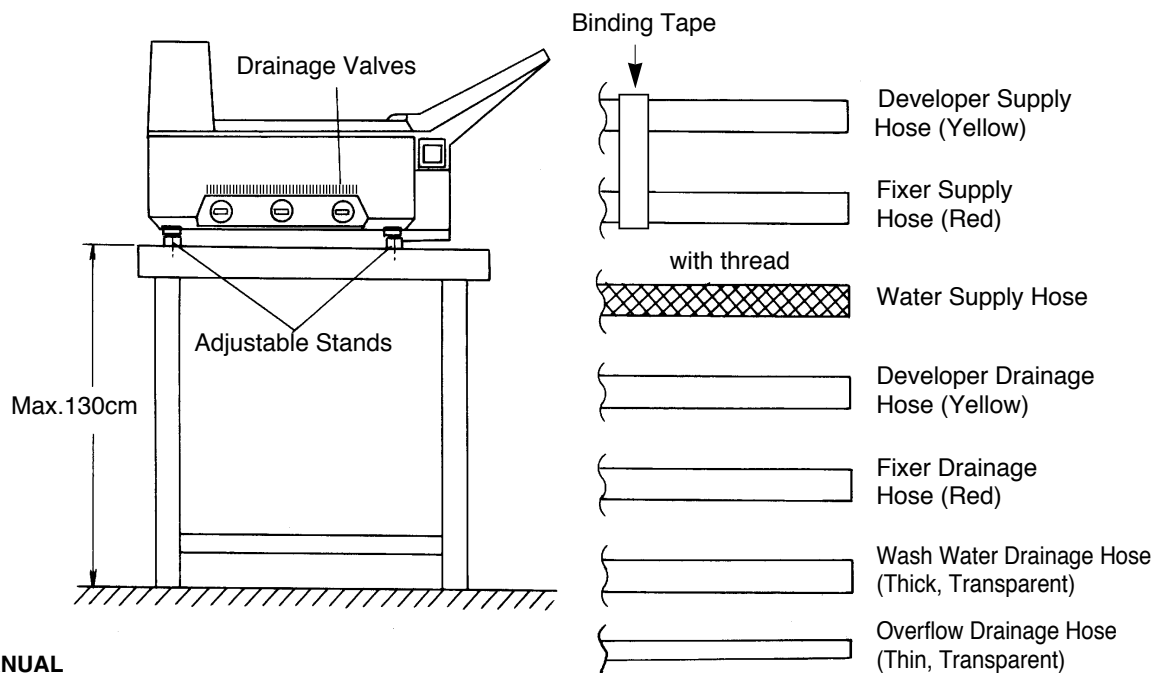

INSTALLATION INSTRUCTIONS AND PRECAUTIONS

13-3. Connecting the Supply Hoses

- ① Connect the supply hoses to the 25 liter replenisher tank.

YellowDEV Supply Hose.

RedFIX Supply Hose.

- ② Use SNP-12-HSO to clamp the hoses to the tank.

NOTE :

Do not extend any of the hoses more than 5 meters in length. If these 12 mm diameter hoses are extended longer than 5 meters, they tend to bend and collapse.

13-4. Connecting the Drainage Hoses

- ① Connect the drainage hoses to the 25 liter replenisher tank.

YellowDEV Drainage Hose

RedFIX Drainage Hose

Transparent(Thick)Water Drainage Hose.

Transparent(Thin)Overflow Drainage Hose

- ② String the chemical and water drainage hoses so that no liquid will accumulate in the hoses between the main unit and the drainage tank or the water drain.

13-5. Power Source and Wiring

- ① Changing the terminal Board to Meet Voltage Requirements

Follow these procedure in changing the connection to terminal board TB1 located on the top of the electrical components unit.

UL Version

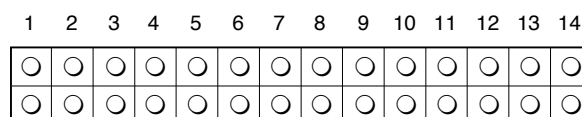

① For AC 120V outlets, connect terminals #5 and #8.

② For AC 115V outlets, connect terminals #5 and #7.

CE Version

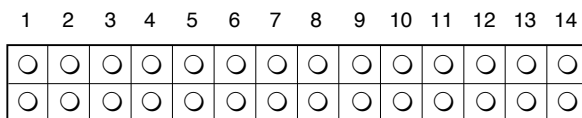

① For AC 240V outlets, connect terminals #5 and #9.

② For AC 230V outlets, connect terminals #5 and #8.

③ For AC 220V outlets, connect terminals #5 and #7.

INSTALLATION INSTRUCTIONS AND PRECAUTIONS

- ② Select an electrical outlet that is equal to or above the required current and voltage to operate the processor and use this outlet for the SRX-101A only.
Insufficient current to the processor may cause overheating and/or smoking.
- ③ The power source voltage to the processor should be within a range of $\pm 10\%$ of the specified requirement. The frequency (Hz) value should be within a range of $\pm 2.5\%$ of the specified requirements.
- ④ Lay the power cord so that it is clear of foot traffic, sharp objects and other equipment.
Damaged plugs and cords may cause the processor to overheat and/or smoke.
- ⑤ To prevent overheating or smoking, do not connect the processor to table top outlets, junction cords or junction outlets.
- ⑥ The power cord provided as standard equipment is 2.6 meters in length. If an extension is needed, use only legally specified (product liability standard) extension cords. Sub-standard extension cords may cause the processor to overheat or smoke.
- ⑦ To prevent electrocution accidents, properly ground the SRX-101A. To avoid the possibility of explosions or electrocution, do not attempt to ground the processor to any of the following objects.

Gas pipes

Lightening rods

Telephone ground wires

Any water line or spigot not permitted by your local water department.

13-6. Room Conditions Around the SRX-101A

- ① The acceptable room conditions for operating the SRX-101A are :
Temperatures between 15: and 30:(59<and 86<
Humidity levels between 30%RH and 75%RH
- ② In order to maintain the above room conditions, the facility where the SRX-101A is located should be equipped with a ceiling mounted ventilation fan and a ventilation opening in the wall below the height of the processor.

Ex. Darkroom Ventilation

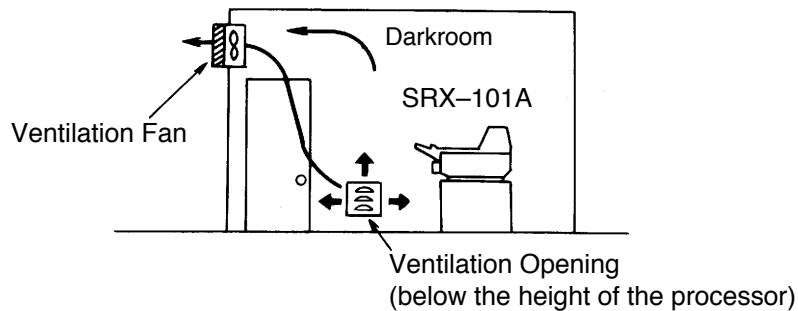

The ventilation wall opening should be as close to the processor as possible and as far away from the ventilation fan as possible. Use light shielding materials for both the fan and wall openings.

- ③ Keep all fluorescent materials and combustible materials (thinner, benzene, gasoline.etc) away from the processor. To prevent fires, store such dangerous materials in another room.
- ④ Divert heat from burners and space heaters away from the processor. Divert forced air from air conditioning equipment away. Being exposed to direct blast of hot or cold air, poor film processing quality may result.

INSTALLATION INSTRUCTIONS AND PRECAUTIONS

13-7. Water Lines

- ① Connect a reducer bushing with a packing to the facility's water utility outlet.
- ② Connect the processor's water supply hose to the reducer bushing.

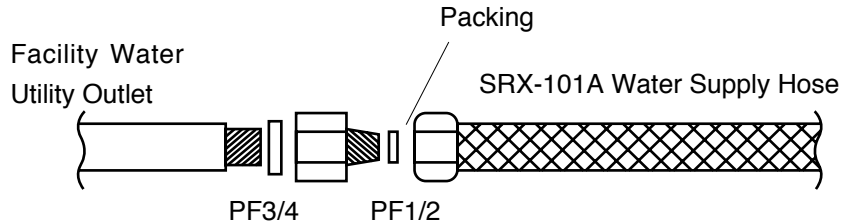

- ③ Acceptable Wash Water Temperature 5°C~30°C(41°F~86°F)
Required Water Flow0.7~1.7 ℓ (0.19~0.47gal.)/min
Required Water Pressure29.4~784kpa(0.3~8kgf)/cm²
- ④ If water pressure is below 29.4kpa(0.3kgf)/cm², over 0.7 ℓ (0.19gal.)/min Wash water cannot be maintained.
In this case, a malfunction may occur. Increase the water pressure.
- ⑤ If water pressure is exceeding 784kpa(8kgf)/cm², use flow restrictor to reduce the water pressure.
Excessive water pressure applied to the water line may cause the damage of the hoses.

13-8. Setting the Feed Tray in Place

- ① Use the pan-head screws provided to attach the feed tray to the main unit.
- ② Control panel can be attached to either side of the main unit.
Select the side which is more convenient to operate, considering the operating environment.

13-9. Cleaning the Racks

- ① Remove the DEV and FIX racks from the main unit.
- ② Scrub each rack(including the rollers) with a wet sponge to remove any dirt or grim and then rinse with plain water. Lean the racks so that the remaining water can evacuate from the racks.

13-10.Leveling the Main Unit

- ① Use a carpenter's level. Turn the adjustable legs supporting the main unit to balance the processor vertically and horizontally.
- ② If the carpenter's level is not available, fill the tanks with a solution up to the indicator mark, and check the level of the solution at 6 different points on the leveling lines which are located at right and left inner side of the DEV, FIX and WASH tank and adjust if necessary.

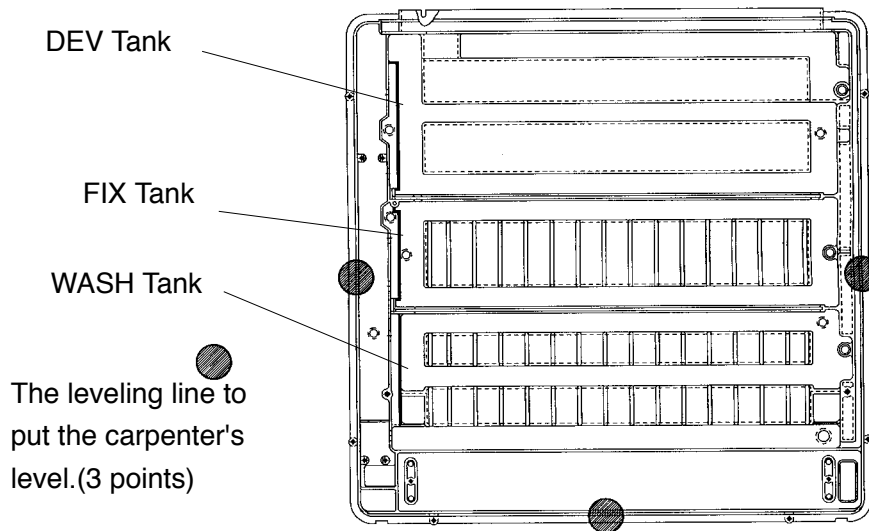

INSTALLATION INSTRUCTIONS AND PRECAUTIONS

13-11. Setting the Racks

Make sure that there is no excess water remaining in the racks before setting them into the main unit. The racks have been designed so that the DEV rack is set first, then the FIX-WASH rack can be inserted. They cannot be set in the reverse order.

Set each rack into the main unit so that the arrows and names on the rack exactly overlap the arrows and tank names on the main unit. (Refer to the diagram below)

If the arrows and names do not exactly match, the rack ribs will not slide into their grooves and the racks will wobble in the tanks.

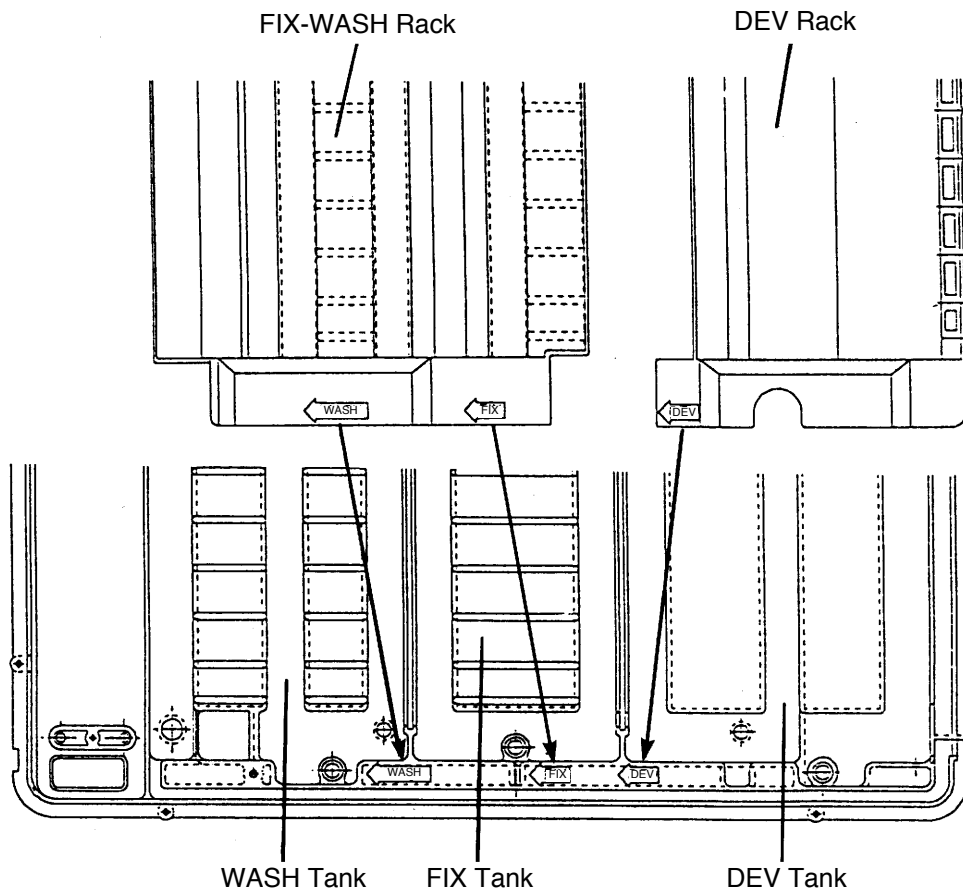

INSTALLATION INSTRUCTIONS AND PRECAUTIONS

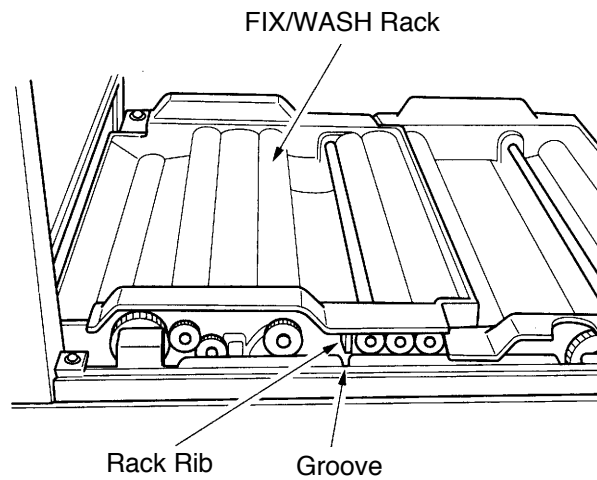
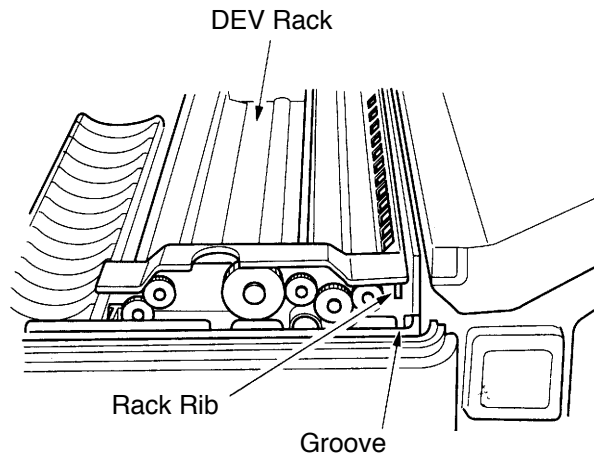

13-12. Mixing the Processing Chemicals

When Using the 25 Liter Replenisher Tank, follow the direction that come with each pack of developer and fixer.

CAUTION

1. The chemistry and starter fluid are dangerous to eyes, can cause skin irritation and damage clothing. Handle them with care. If you accidentally splash chemistry on your skin or clothing, immediately wash the stained areas with water. If you splash any of these chemistry in your eyes, immediately wash with water and get professional medical treatment.
2. To avoid accidents, strictly follow the directions for handling and mixing of chemistry.

INSTALLATION INSTRUCTIONS AND PRECAUTIONS

13-13. Filling the Tanks

a. Normal Procedure

- ① Remove the top cover of the main unit.
- ② Close all the drainage valves
- ③ Open the facility's water utility valve.
- ④ Plug in the power cord.

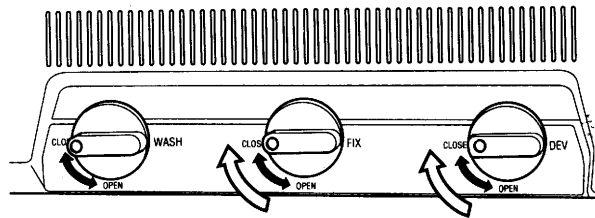

- The RUN Button Lamp on the control panel will light up.

NOTE : Do not press the RUN Button.

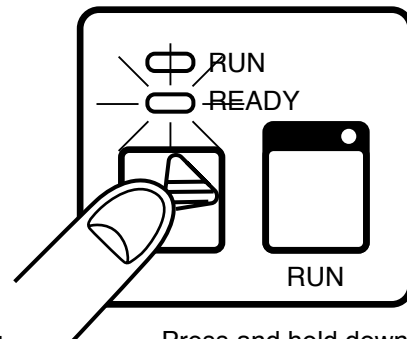

Press and hold down about 5 seconds

- ⑤ Press and hold down the Replenishment Button (about 5 seconds) until the READY Lamp begins flashing.
- The tanks will begin to be supplied with processing solution until the READY Lamp stops flashing, indicating that the tanks are full. This process takes about 22 minutes at 50 Hz and about 18 minutes at 60 Hz.
- ⑥ Use the beaker(measuring cup) provided to measure out the specified quantity(ex. 78 ml) of starter.
- ⑦ Pour the starter into the DEV tank through the starter fluid gap shown as below.
- ⑧ Close the top cover.

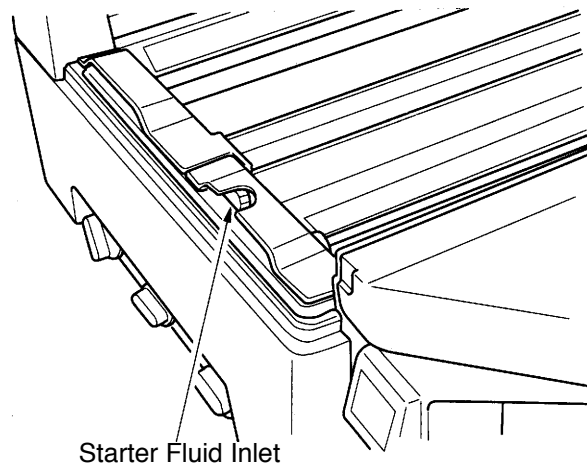
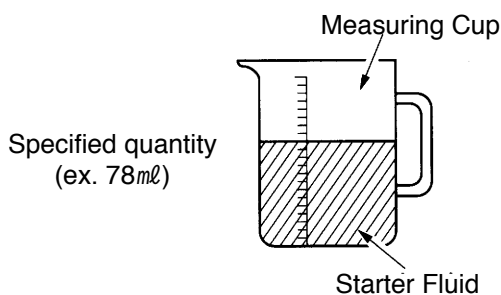

INSTALLATION INSTRUCTIONS AND PRECAUTIONS

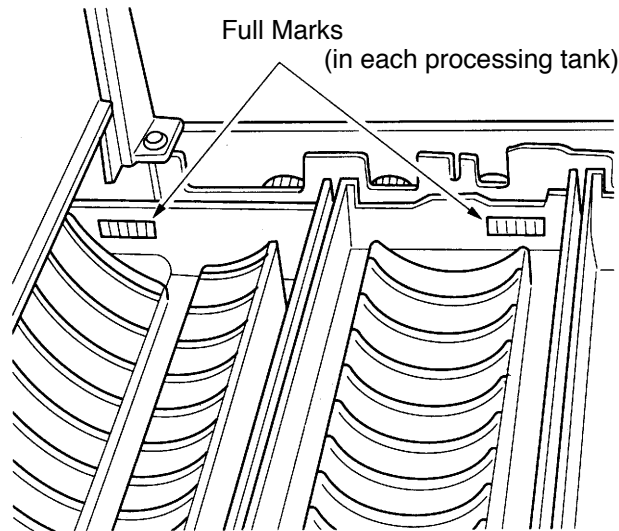

b. Quick Procedure

If you are in a hurry to fill the tanks, you can use the funnel provided to fill the tanks manually.

Begin the following procedures with only the DEV rack set in place.

- ① Push the OFF side (○ side) of the power breaker.
- ② Fill the FIX tank with solution up to the full mark, being careful not to splash any of the solution into the DEV tank.

NOTE: Wash the funnel thoroughly after use.

- ③ Set the FIX-WASH rack into the tank, being careful not to splash any of the solution.
- ④ Fill the DEV tank with solution to just slightly overflow the tank.
- ⑤ Use the beaker provided to measure out the specified quantity (ex. 78 ml) of starter.
- ⑥ Pour the starter into the DEV tank through the starter fluid inlet.

NOTE :

"Air rock" may occur after finishing this procedure. Be sure to activate the Circulation pump to check if the solutions circulate normally.

13-14. Operation Testing

- ① Press the RUN Button ON.
- The RUN Lamp will light up.
- ② Wait until the READY lamp lights up.
- ③ Remove the main unit's top cover.
- ④ As soon as the processor is READY, insert a few sheets of test film through the feed tray and check the following operations :
 - a. Are the rollers rotating smoothly?
 - b. Are the processing solutions circulating in the tanks?
 - c. Is the DEV temperature at the correct level when the READY lamp comes on?
 - d. Is the test film entering the processor smoothly?
 - e. Is the alarm sounding after the trailing edge of the film enters the processor?(See p. 50)
 - f. Are there any leaks in piping system?

INSTALLATION INSTRUCTIONS AND PRECAUTIONS

13-15. Removing Trapped Air from the Supply Hoses

- ① Turn on the RUN Lamp and keep pushing READY button to activate the auto-fill function until the READY lamp's flashing pattern changes.
- ② Lift the supply hose up so that any trapped air will move towards the processor.
Refer to the following diagram.
- ③ Gradually lift the hose to move the trapped air towards the processor, the trapped air will eventually be released into the tanks.
- ④ After the trapped air is released, push RUN button OFF and reset the solution replenish mode.

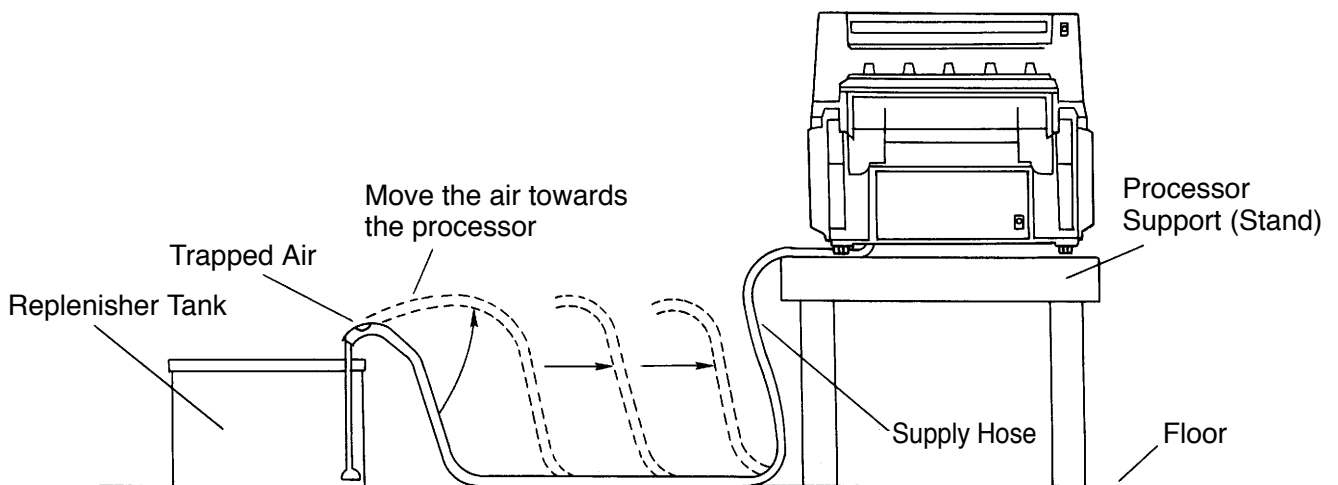

13-16. Wash Basin Specifications

- ① Install a wash basin nearby the processor to keep it clean and to mix film processing solutions.
- ② The wash basin should be at least 700mm (2.3 ft) long, 500mm (1.64 ft) wide and 200mm (0.66 ft) deep.
- ③ The basin should be made of material highly resistant to concentrated acid and alkaline solutions. We recommend either stainless steel (SUS 304, 316) or hard polyethylene.
- ④ We also recommend a hot water line, since the processing racks are much easier to clean thoroughly with warm water.
- ⑤ Also use a wash basin with a plug, since heavily soiled racks are best cleaned by soaking them in warm water.

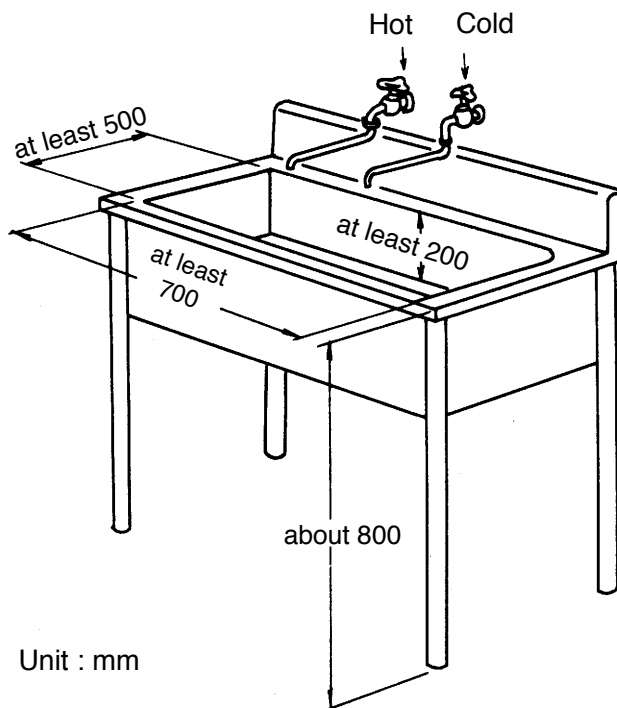

Reference data of each Rack

Rack	Dimensions (mm)			Weight (kg/lb)
	W	D	H	
DEV	560	190	85	2.2/ 4.8
FIX-WASH	560	270	80	2.0/ 4.2
DRY	580	125	210	5.1/11.2

CHANGING PROCESSING CONDITIONS

14. Changing Processing Conditions

The following listing indicates the conditions that were preset at the factory.

When any changing is needed or customer asks to do that, refer to the following listing.

Condition		Factory Setting	Change Procedure
Process Cycle Time		120 Sec.	Set DIPSW1-3,4 according to the table on p 46.
DEV Temperature		34°C	Adjust the volume on the temperature control board. See p 51.
DRY Temperature		230°C	
Replenish Amounts	DEV	40ml/24 x 30cm(10 x 12inch)	Set DIPSW1-7,8 according to the table on p 46.
	FIX	70ml/24 x 30cm(10 x 12inch)	
Standby Time		10 min.	Set DIPSW1-5,6 according to the table on p 46.
Frequency		50/60 Hz	Set DIPSW1-2 according to the table on p 46.

NOTE :

1. There are three process cycle times to choose from : 90, 120, and 180 sec.
2. The developer temperature may be set between 29°C and 37°C.
3. The drying temperature (the heater surface temperature) may be set between 210°C and 250°C.
Adjustments in temperatures are made necessary by differences in room conditions around the processor.
4. Replenish amounts may be adjusted to -20%, -40%, or +30% of the preset values.
5. There are three standby times to choose from : 10 min, 30min, and 0 min (continuous operation).
If no film enters the processor for 1 hour from READY for processing (READY Lamp ON), the SRX-101A will automatically switch over the standby mode, during which the drying heater will be switched OFF and ON at 5 minutes intervals.
As soon as a sheet of film enters the processor, the SRX-101A will automatically switch from standby into the normal operation mode.
6. The following table shows the standard developer temperature levels for each processing cycle time.

Cycle Time (sec.)	DEV Temperature (°C)
90	36
120	34
180	(for mammography)

15. SRX-101A Customer Presentation Guide

After the SRX-101A has been installed, explain the following points to the customer.

15-1. First, during your presentation check each of the points outlined in the following flow chart.

Self introduction

- 1 Introduce yourself.
- ↓ 2 Thank the customer for purchasing the SRX-101A and assure him/her that Konica will do all that we can to be of service.

Features and Specifications of the SRX-101A

- 1 Make the customer feel confident about the decision in purchasing the processor.
- ↓ 2 Make your general explanation of the processor as brief and concise as possible.

Names and Function of the Main Unit's Components

- 1 Explain these points using the Operation Manual.
- ↓ 2 Point out each component when explaining it.

How to Mix the Processing Chemicals

- 1 Explain using the directions on the chemical packages.
- ↓ 2 Clearly explain all the precautions to be taken when mixing the solutions.
- 3 If the customer will be using a chemical mixer, explain how to operate it.

Operational Procedure

- 1 Explain these points using the Operation Manual.
- ↓ 2 Have the customer go through the operation process and make sure he or she remembers all the steps to be taken.

How to Handle the Accessory Equipment

- 1 Explain these points using the Operation Manual.
- ↓

Cleaning

- 1 Explain these points using the sections on cleaning in the Operation Manual.
- ↓ 2 Emphasize all the precautionary measures to be taken in the cleaning process.

Maintaining Optimum Room Conditions around the SRX-101A

- 1 Emphasize all the precautions to be taken in maintaining optimum operating conditions both inside the darkroom and out.
- ↓

SRX-101A CUSTOMER PRESENTATION GUIDE

Troubleshooting



- 1 Explain these points using the relevant sections in the Operation Manual.
- 2 Try to explain how to respond to errors in the simplest way possible.
- 3 Clearly indicate to the customer where and whom to contact in case of an operational problem or complaint.

Check and Maintenance



- 1 Explain these points using the relevant sections in the Operation Manual.

Shutdown Procedure



- 1 Explain these points using the relevant sections in the Operation Manual.

Questions and Answers



- 1 Answer all questions from the customer with confidence.
- 2 If you cannot answer a certain question on the spot, make clear to the customer when you can answer.

Warranty



- 1 Remind the customer that the SRX-101A is guaranteed for a certain period from the date of installation.

Conclusion

- 1 Make sure to thank the customer for taking the time to listen to your presentation.

15-2. Make Sure of the Following Points Before Your Presentation to the Customer.

- (1) Is this the first time the customer has purchased an automatic film processor?
Is the SRX-101A a replacement processor?
If it is being purchased for the first time, give a more detailed presentation.
If it is a replacement processor, first check the type of processor that was used previously.
Then give your presentation so that the customer understand the similarities and differences between operating the previous processor and running the SRX-101A.
- (2) If the SRX-101A is a replacement processor, make sure that you are familiar with the features of the previously used model; for example, its processing speeds and solution temperature levels. (Always keep in mind ways to maintain the film processing conditions that the customer has become used to.)
- (3) Check beforehand the space where the SRX-101A is to be installed, as well as the operating environment (exhaust devices, temperature/humidity conditions, etc.) Also check to see if there is a suitable place for electrically grounding the main unit.
- (4) Check beforehand the processing speeds, film and sensitized paper the customer intends to use.
- (5) Find out the approximate number of film sheets that will be processed each day. Then calculate the amount of processing chemicals and film that will be needed, so that insufficiencies in supply will not arise during operation.
- (6) Check beforehand to see that the processing chemicals and the film to be used are compatible. Caution the customer concerning any incompatible combinations. Make sure that you explain clearly the reason why the incompatible materials cannot be used together.
- (7) Read the catalogues and Operation Manual and understand the specifications and features of the SRX-101A thoroughly before giving your presentation.

15-3. Explaining How to Use the SRX-101A

Give your presentation using the SRX-101A operation manual.

- (1) Self Introduction
 - ① Introduce yourself.
 - ② Thank the customer for purchasing the SRX-101A and let him/her know that Konica will do all that it can to be of service.
- (2) Features and Specifications
 - ① Explain the features and specifications of the processor.
 - Emphasize the special features of the SRX-101A and make the customer feel confident his/her facility has made the right decision in purchasing this particular processor.
 - Make sure to mention that the SRX-101A is a state-of-the-art medical film processor, the best available.
- (3) Names and Functions of the Main Unit's Components
 - ① Explain the main unit's components.
 - ② Include in your presentation an explanation of the processor's special features in relation to the components.

SRX-101A CUSTOMER PRESENTATION GUIDE

- ③ Point out each component as you explain it.
- ④ Study the Operation Manual thoroughly so that you can answer any questions correctly and informatively.
 - If by chance there is a question that you cannot answer immediately, make sure to inform the customer when you will have an answer ready.

15-4. How to Mix the Processing Chemicals

- ① Explain how to mix the developer and fixer replenisher solutions using the replenish tanks.
 - Go through the directions printed on the chemical packages.
 - Explain clearly the differences between the developer and fixer replenisher solutions, so that the customer will not confuse them during operation.
 - Explain the mixing procedure along with the following precautions :
 - a) Do not reverse the steps in the developer replenisher (Chemical A, Chemical B Chemical C) mixing procedure.
 - b) Do not reverse the steps in the fixer replenisher (Chemical A, Chemical B) mixing procedure.
 - c) Mix the chemicals thoroughly.
 - d) Use only the amount of water specified on the package.
 - e) Explain what measures to take if processing solution comes into contact with the skin or eyes.
- ② If the customer will use a chemical mixer, explain its features and operating procedures.
 - More and more customers are using chemical mixers these days. So it is a good idea to become familiar with their features and operation.

15-5. Operational Procedures

- ① Explain how to operate the SRX-101A.
 - Be sure to explain these points using the Operation Manual.
 - Demonstrate how to switch both the building's power breaker and the main unit power switch ON and OFF. Have the customer actually perform this procedure until he/she remembers all the steps involved.
 - Make certain that the processor's initial settings are correct.
 - Explain the operational procedures in the following order, emphasizing how to use the control panel on the main unit.
 - a) Take this opportunity to recheck the cycle time and processing conditions you set during installation.
 - b) How to select the standby modes.
 - c) How to supply replenisher and processing solution.
 - d) Other procedures.
 - Explain what film sizes and types are compatible with the SRX-101A.
 - After the processing solution temperatures have reached their operational levels, run a few sheets of already developed 24x30cm(10x12inch) film through the processor and explain how the film is transported.
 - Explain how to insert single-face emulsion film.

15-6. How to Handle the Accessory Equipment

- ① If the customer has chosen to use any optional accessory equipment, explain how it functions in relation to the SRX-101A.
 - Explain these points using the Operating Manual.
- ② Explain how to hook up optional equipment.
 - If no option will be used, make your presentation as concise and brief as possible.

15-7. Cleaning

- ① Explain all the points necessary in keeping the SRX-101A clean.
 - Explain these points using the Operation Manual.
- ② Explain the differences between the way of cleaning the bakelite rollers that are required to be done everyday, once a week, once a month, and once every three months.

15-8. Maintaining Optimum Room Conditions around the SRX-101A.

- ① Explain clearly all the precautions to take in maintaining optimum operating conditions around the processor.
 - Using an air circulation fan.
 - How to use the solution recycling tanks.
 - Checking the main unit exhaust.
 - Checking the room temperature and humidity around the processor.

15-9. Troubleshooting

- ① Explain the troubleshooting procedures.
 - Explain these points using the relevant sections in the Operation Manual.
 - Explain the measures to be taken for every error that may occur.
 - Show the easiest ways of troubleshooting.
 - Clearly indicate to the customer where and whom to contact in case of an operational problem or complaint.
 - Explain the content of the free-of-charge after-service schedule that you intend to follow.

15-10. Maintenance

- ① Using the Operation Manual, explain how to maintain the processor at optimum operating conditions.
 - Make sure to impress on the customer how important these periodical maintenance checks are in preventing operational errors.

16-11. Shutdown Procedure

- ① Explain the maintenance checks that should be carried out when the processor is shut down.
- ② Explain these points using the relevant sections in Operation Manual.

15-12. Questions and Answers

- ① Answer all questions from the customer with confidence.
- ② If you cannot answer a certain question on the spot, make clear to the customer when you will have an answer ready.

15-13. The Warranty

- ① After installation and check have been completed, refer the customer to the clause in the warranty that says, "The SRX-101A has been handled over to you on this date,....., installed and checked properly with all its components and parts in optimum working condition."
 - If for some reason the processor cannot be handed over to the customer under the above stipulations, explain the details and relate when it will be ready to be handed over. Make sure that the customer agrees to these conditions.

15-14. Conclusion

- ① Urge the customer to read the Operation Manual over thoroughly before trying to operate the SRX-101A.
 - Make sure that the customer knows where and whom to contact if there is something unclear in the Operation Manual.
- ② Make the customer feel confident about operating the processor easily and safely.
- ③ Thank the customer for taking the time to listen to your presentation.

16. SRX-101A Light Shield Installation Manual

16-1. Light Shield Kit Contents

Check the contents against this list upon delivery.

ID.No.	Parts Name	Qty	Remarks
1	Foam packing(thickness 10mm)	9	L=1000mm, cut at adequate length of light shield plate and wall.
1A	Foam packing(thickness 10mm)	1	Cut at L=530mm and use.
2	Light shield plate	1	
3	Foam packing(thickness 10mm)	2	Cut at L=20mm and use.
3A	Foam packing(thickness 10mm)	1	Cut at L=450mm and use.
3B	Foam packing(thickness 5mm)	2	Cut at L=200mm and use.
4	Foam packing(square)	4	
5	Foam packing(thickness 3mm)	4	Cut at L=165mm and use.
5A	Foam packing(thickness 3mm)	2	Cut at L=225mm and use.
5B	Foam packing(thickness 3mm)	1	Cut at L=560mm and use.
6	Light shield plate	1	
7	Foam packing(triangle)	2	
8	Light shield plate	1	
9	Light shield plate	1	
10	Foam packing(thickness 20mm)	1	Cut at adequate length.
10A	Foam packing(thickness 20mm)	2	Cut at adequate length.
11	Magnet mounting plate	1	
12	Magnet mounting plate	1	
13	Magnet catcher	1	Tochigiya, TL-238 No.2.
14	Foam packing(pentagonal)	2	
15	Magnet mounting plate	1	
16	Switch box	1	
17	Speed nut M4	8	
18	Gromet with membrane	10	Tochigiya, MG-9.
19	Light shield rubber	1	
a	Pan-head screw M4 x 6		
b	Truss-head screw M4 x 8		
c	Pan-head screw M6 x 20		
d	Plain washer $\phi 6$		
e	Hexagon nut M6		

SRX-101A LIGHT SHIELD INSTALLATION MANUAL

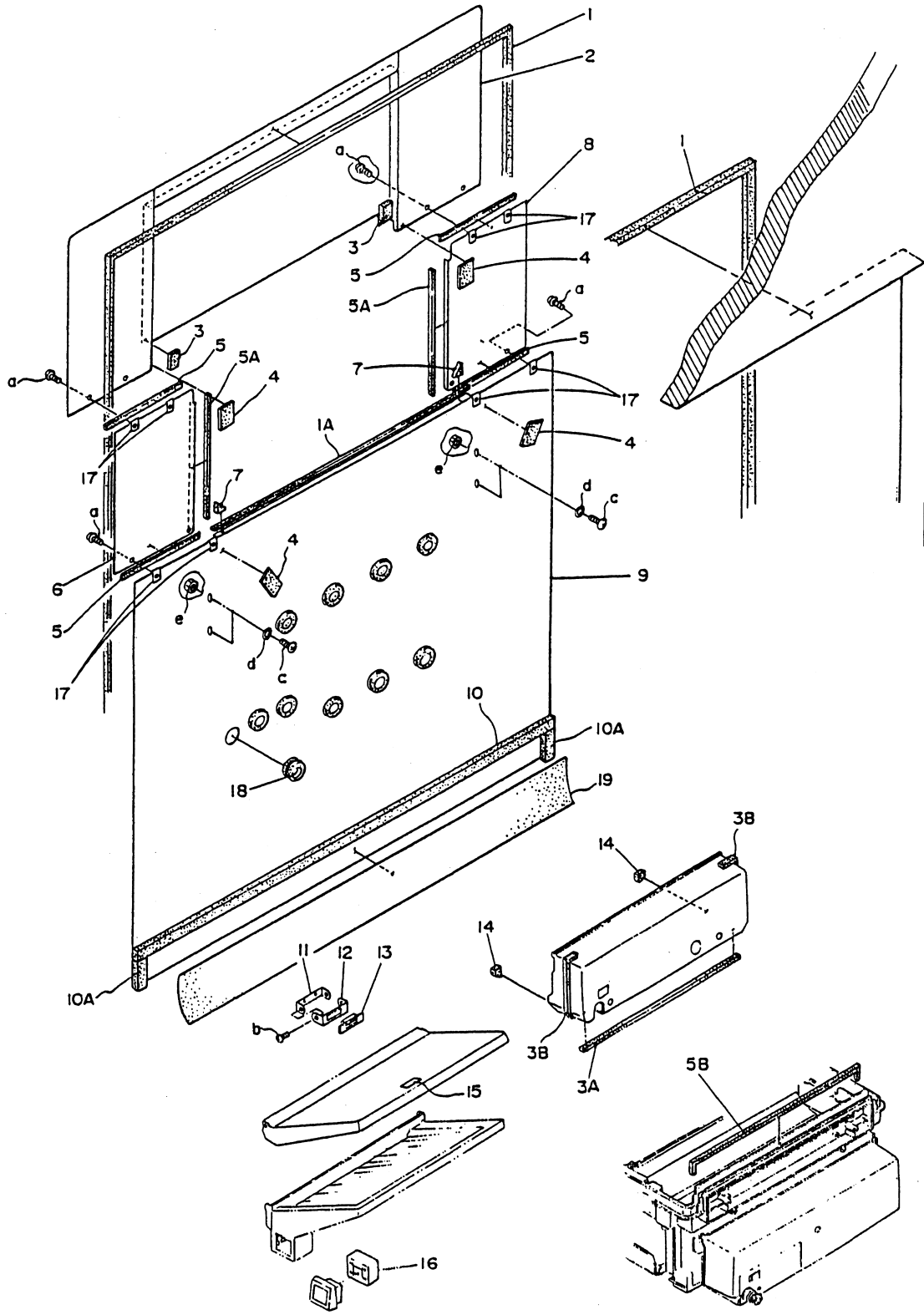

17. Installation Procedure

Preliminary Notes

1. Assemble the shield on the light room side of the processor near the access opening in the partition.
2. Assemble the processor main unit stand before assembling the light shield.
3. Before installing the SRX-101A, make sure to position the main unit stand so that the replenisher tanks are easily accessible. The main stand has crossbars on three of its four sides. The side without a crossbar is the side providing easy access to the replenisher tanks for mixing new processing solutions. Take this point into consideration when deciding which side of the main unit on which to install the light shield assembly.
4. The light shield can be installed on any of the main unit stand's four sides.
 - ① Make sure that all of the SRX-101A processing tanks are empty.
 - ② Place the SRX-101A main unit on its stand.
 - ③ Adjust the two legs on the insertion slot side of the main unit to a height of 25mm. Then slide the main unit all the way in the direction of the insertion slot so that the legs hit the safety stops on the stand.

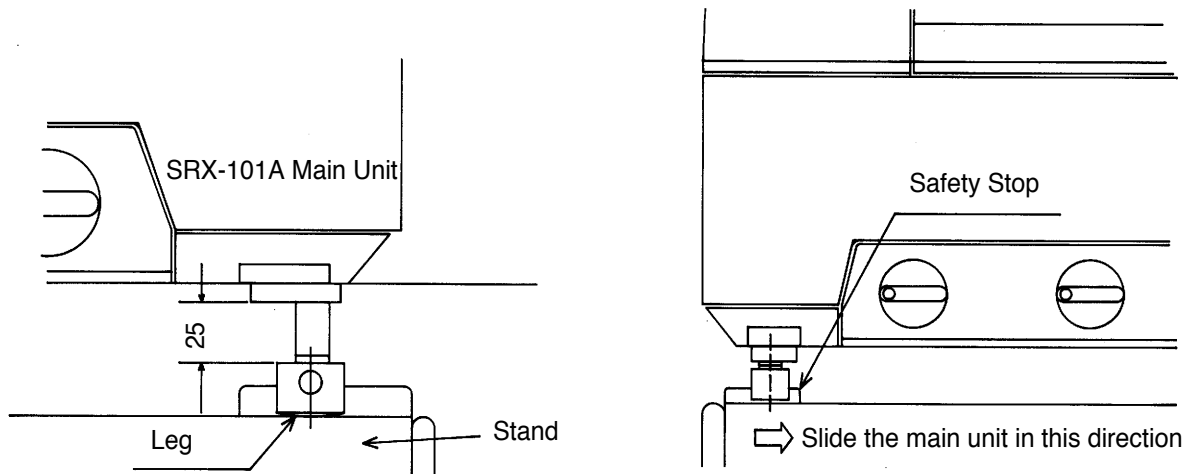

- ④ Remove the electrical components unit's outer and inner covers. Disconnect the control panel lead wire connector from the CPU board. Use a stubby Phillips screwdriver to remove the screw holding the round wire terminal in place.
- ⑤ Remove the film insertion table, and then remove the control panel from the film insertion table.
- ⑥ Remove the top cover. Cut a piece of packing(A) [thickness 3mm] into a strip of 560mm long and attach it to the slot in the main unit for the top cover. (See the diagram right)

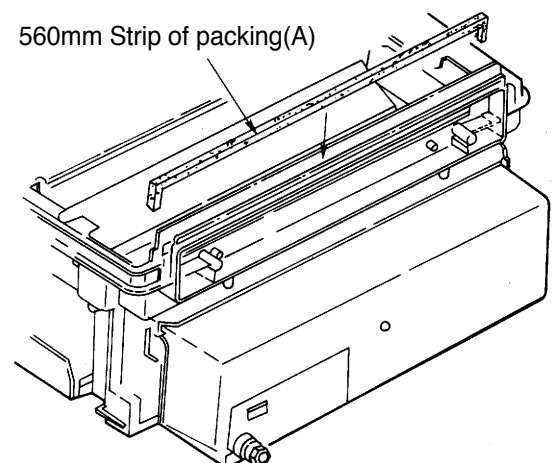

INSTALLATION PROCEDURE

- ⑦ Cut a piece of Packing(D)[thickness 10mm] into a strip of 530mm long. Attach it to the Lower Light Shield as shown in the diagram below. Attach 4 clip nuts at the top edge of the Lower light Shield, adjusting the position against the hole, fix the Lower Light Shield to the main unit stand with M6 x 20 pan-head screws, flat washers($\phi 6$) and hexagonal nuts.

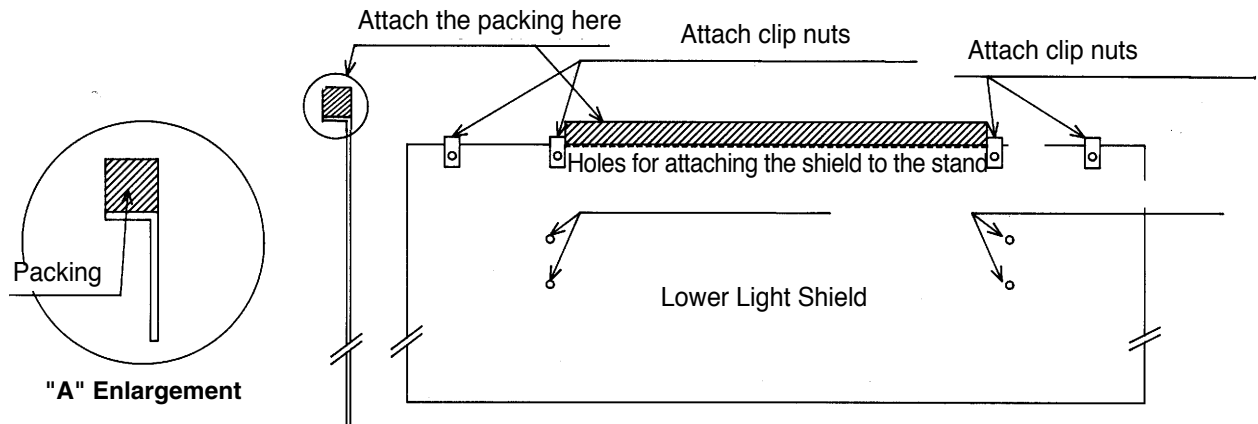

- ⑧ Cut two pieces of Packing(A)[thickness 3mm] into strips of 165mm long, and attach them to the bottoms of the Left and Right Shield. Cut two more pieces of Packing(A)[thickness 3mm] into strips of 225mm long and attach them to the sides of the Left and Right Light Shields as shown in the diagram below. Attach two clip nuts onto each top edge of the Left and Right Light Shields adjusting the position against the hole. Using four M4 x 6 pan-head screws from the light room side of the shields to fix the Left and Right light Shields to the Lower Light Shield.

Note : The right Light Shield is the one with the manufacturing date stamped on it.

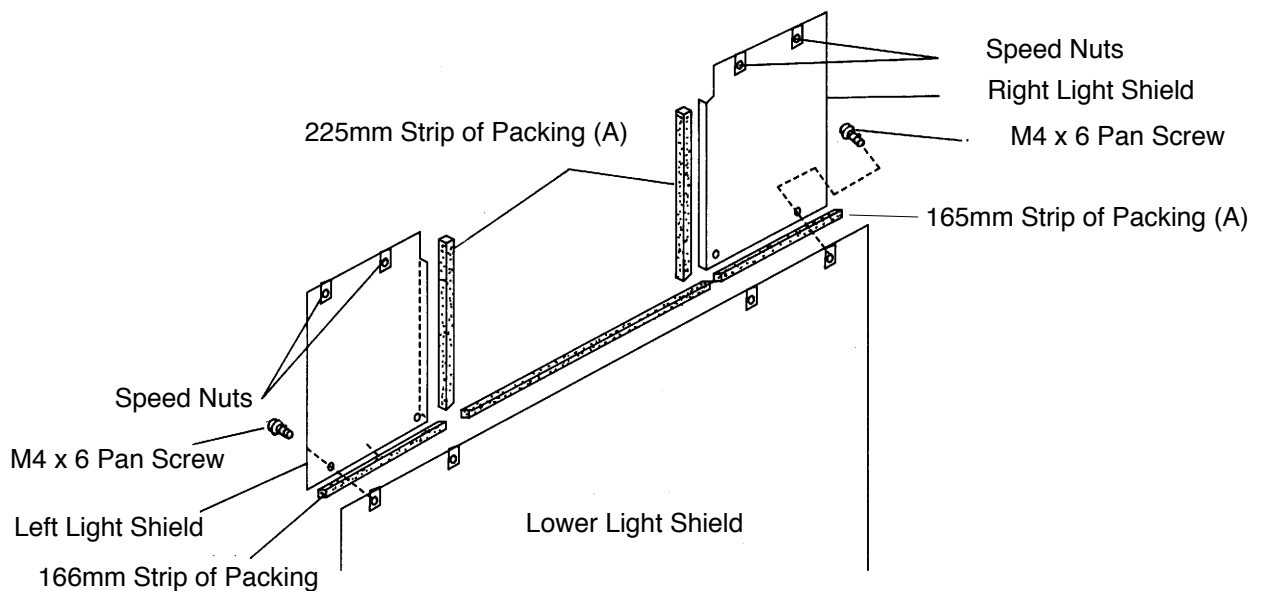

INSTALLATION PROCEDURE

- ⑨ Cut a piece of Packing(A)[thickness 3mm] into a strip of 165mm long, and attach it to the Upper Light shield, and fix it to the light shield panel(right and left) using the speed nuts 4 pieces of M4 x 6 pan screws from the light room side.

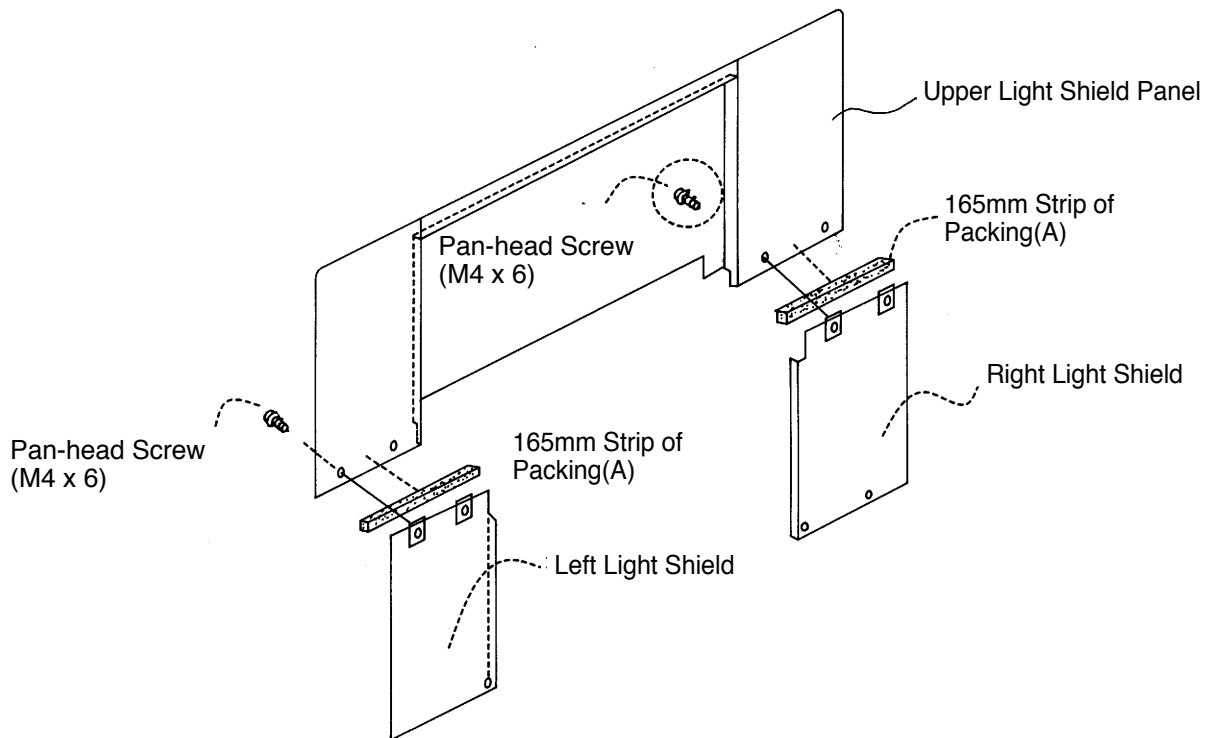

- ⑩ Cut pieces of Packing(D)[thickness 10mm] into two strips of 20mm long and attach them to the left and right corners of Upper Light Shield as shown in the diagram below(left).

- ⑪ Attach the triangle-shaped Packing(E) to the corners as shown in the diagram below(right).

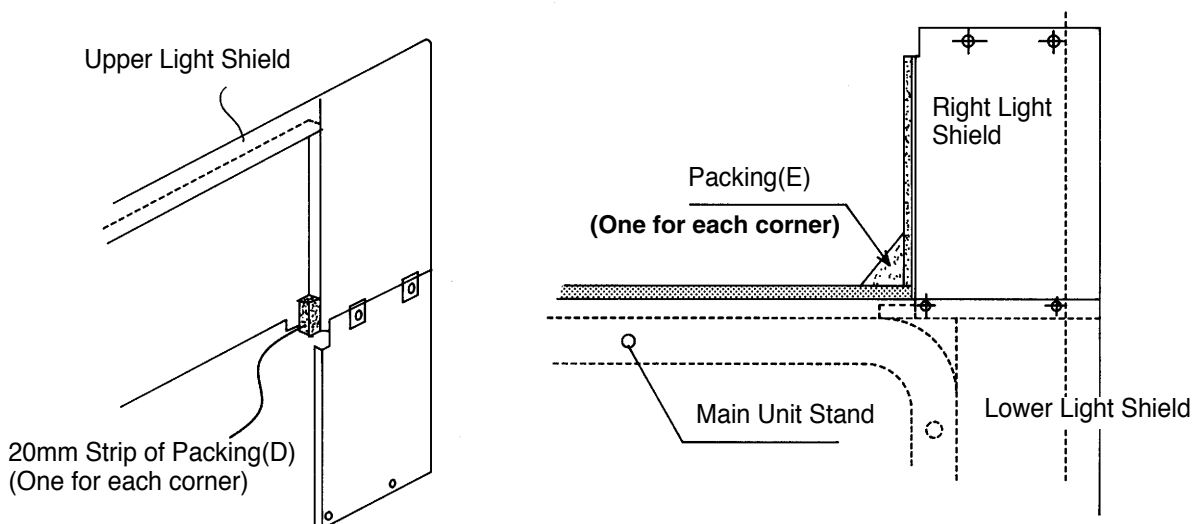

INSTALLATION PROCEDURE

- ⑫String the control panel lead wire through the hexagonal hole in the switch box(notch facing down) so that the control panel is protruding out of the hole.

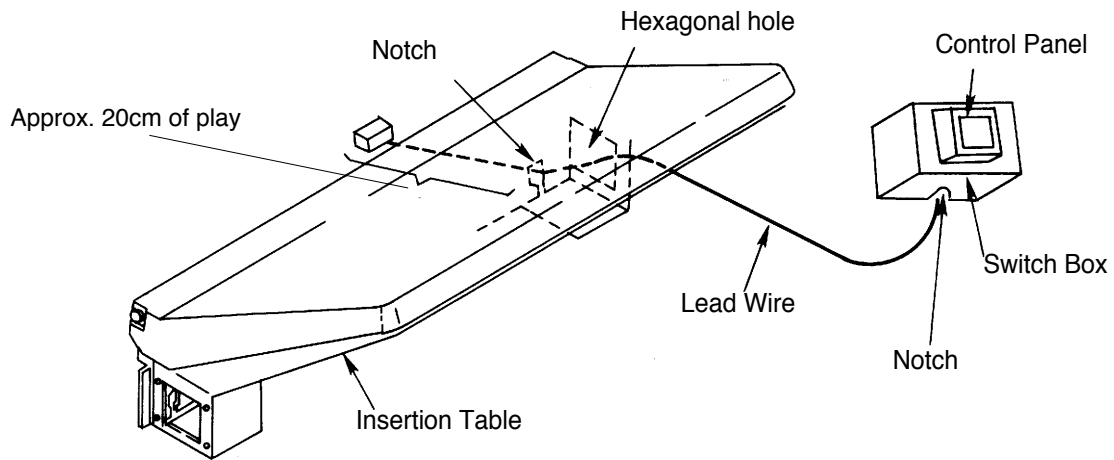

- ⑬String the connector end of the lead wire through the hexagonal hole in the film insertion table for the control panel and the notch provided. Make sure you have about 20cm of play in the wire.
- ⑭Now bring the film insertion table up against the SRX-101A main unit, and string the connector end of the lead wire through the elongated hole in the main unit until the connector is hanging in front of the CPU board. At this point, fix the film insertion table to the main unit with the screw provided.
- ⑮Reconnect the lead wire to the CPU board and fix the ground wire terminal with a screw. Make sure that there is enough play in the wire so that the CPU board is not being pulled or strained.
- ⑯Attach the control panel switch box to a convenient place on the light shield panel.

Note : The control panel may also be attached directly to either the left or right side of the film insertion table, though it will not be easily seen.

- ⑰Attach Packing(G) to the right and left hand sides of the outer cover of the electrical components as shown in the diagram below.

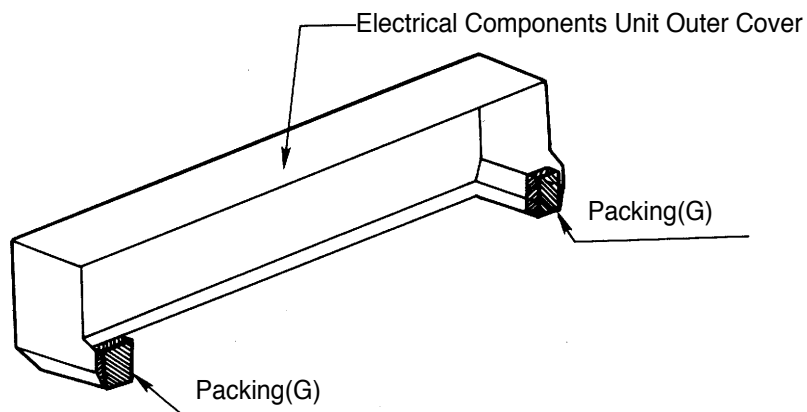

INSTALLATION PROCEDURE

- ⑱ Put the inner cover and outer cover of the electrical components unit back to the original position.
- ⑲ There will be an area uncovered by the outer cover between bottom of the components housing and the bottom of the light shield. Cut a piece of Packing(D)[thickness 5mm] into a strip of 450mm long and attach it to the bottom of the electrical components housing.

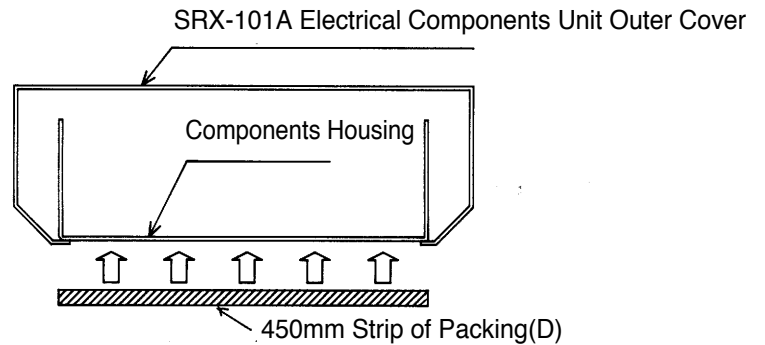

- ⑳ Attach the square-shaped Packing(F) to the left and right sides of the light shield panel.
(4 pieces in total)

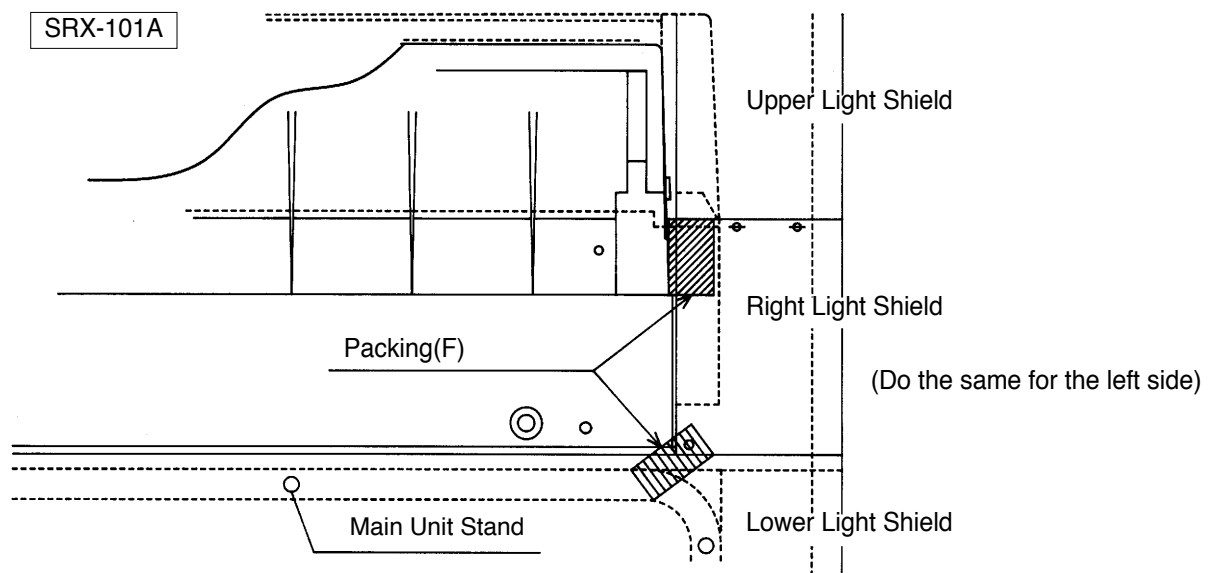

- ㉑ Cut pieces of Packing(C) into two strips of 200mm long and attach them to the left and right sides of the light shield panel around the electrical components unit cover.

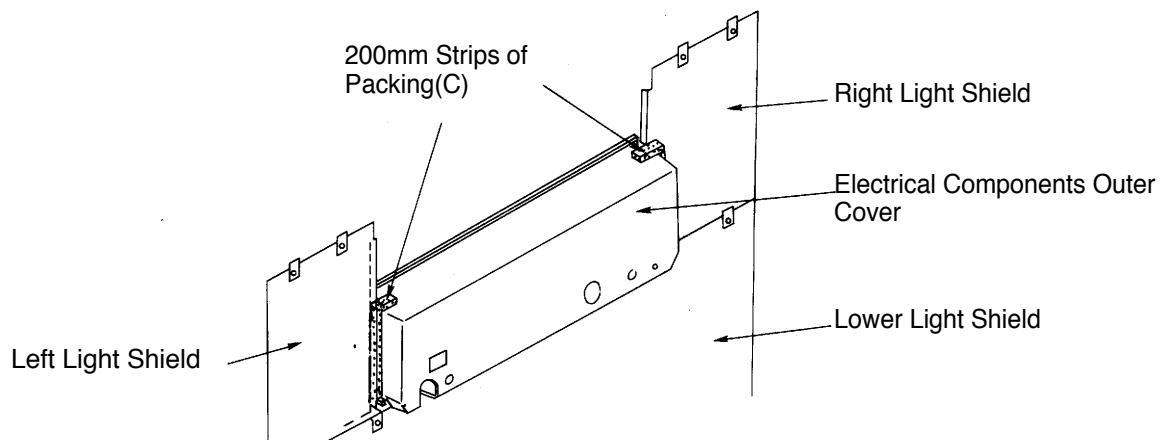

INSTALLATION PROCEDURE

- ② Attach Packing(D)[thickness 10mm] around the opening in the partition and light shield panel. Attach the packing only to the upper, left, and right sides of where the wall and light shield panel will meet.

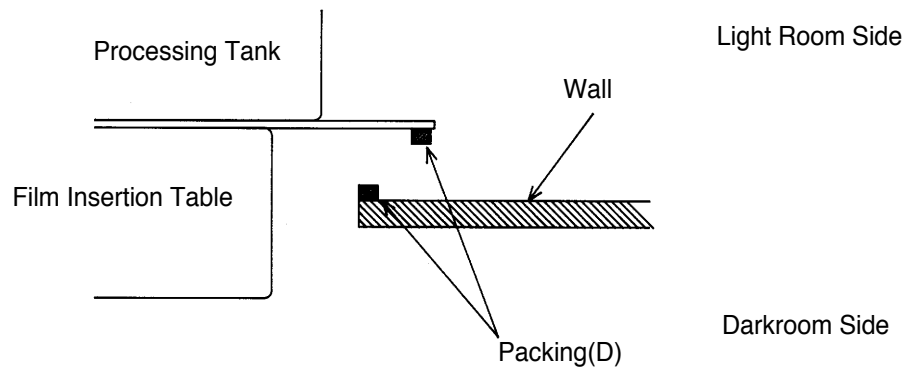

- ③ Lower the insertion table side legs so that the SRX-101A is leveled. Taking special care of the unit's left and right side position, move the processor up against the partition, and then level the unit once again.

Notes :

1. Push the light shield up against the partition so that it is bowed slightly towards the darkroom. This position will give the best light shielding results.
2. If the unit cannot be leveled with only the adjustment bolt on the support, shim the support up using material that will not change shape, like steel plate.

- ④ Attach the light shield rubber lining to cover the opening between floor and the bottom of the light shield panel as below. Cut Packing(B)[thickness 20mm] into a block whose length will match the rubber lining, and stick it to the rubber lining.

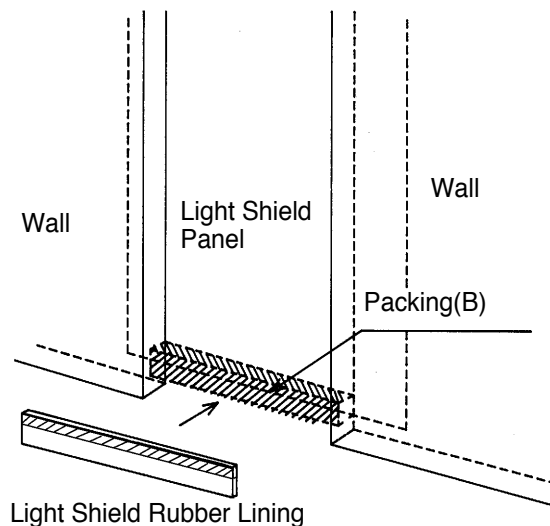

INSTALLATION PROCEDURE

- ②⑤ Attach the magnetic catch to the center for the Upper Light Shield.
- ②⑥ Attach the steel plate to the film insertion table cover so that it hits the magnetic catch when the cover is folded up. (See the diagram below)

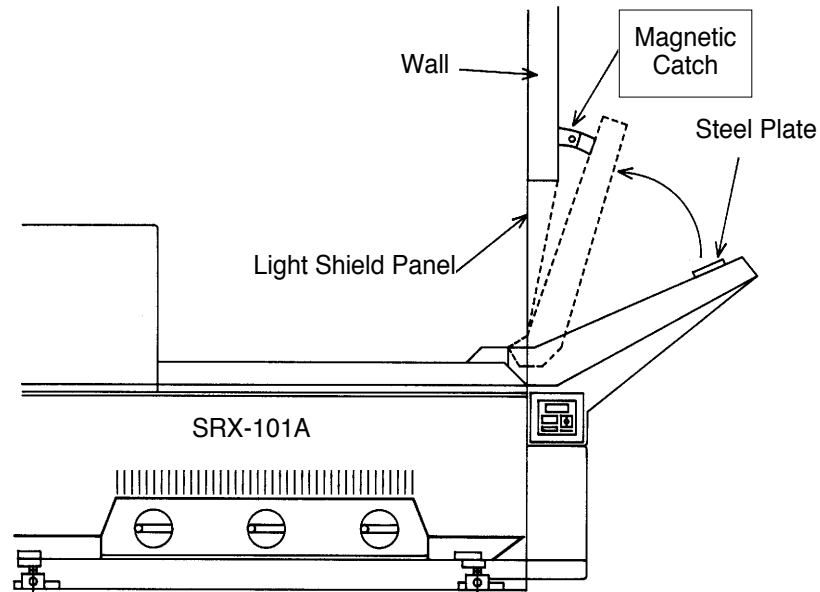

- ②⑦ Open (fold up) the film insertion table cover and make sure that the magnetic catch is strong enough to hold it open while operating the SRX-101A.
- ②⑧ Put back the top cover and make sure that the light shield is functioning properly from the darkroom side.

INSTALLATION PROCEDURE

- 4) Fix the knob plate with the three screws after removing a round plate. (Fig. C)
- 5) Connect the connector JP18 to the JJ18 on the CPU board and the earth (ground) wire. (Fig. C)

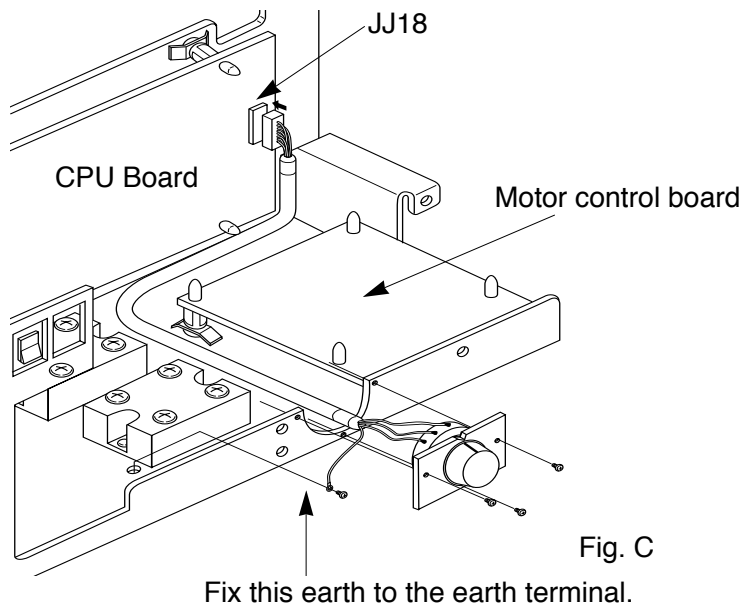

- 6) Adjust the pointer of the knob at the notch of the knob plate. (Fig. D)
- 7) Assemble the covers onto the main body with the knob pointer fixed at the center (Fig. A).
Pay attention to keep the knob not contracted with the surrounding cover.
- 8) Stick the dial plate with the knob pointer matching at 34 scale of the dial plate. Pay attention to keep the knob not contracted with the dial plate. (Fig. E)

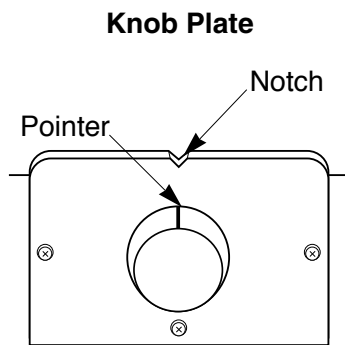

Fig. D

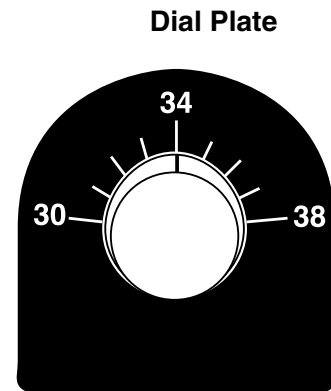

Fig. E

INSTALLATION PROCEDURE

■Adjusting Procedure

1) Checking of the CPU board (Fig. B)

Check the Jp1 on the CPU board if its pins 2-3 are selected.

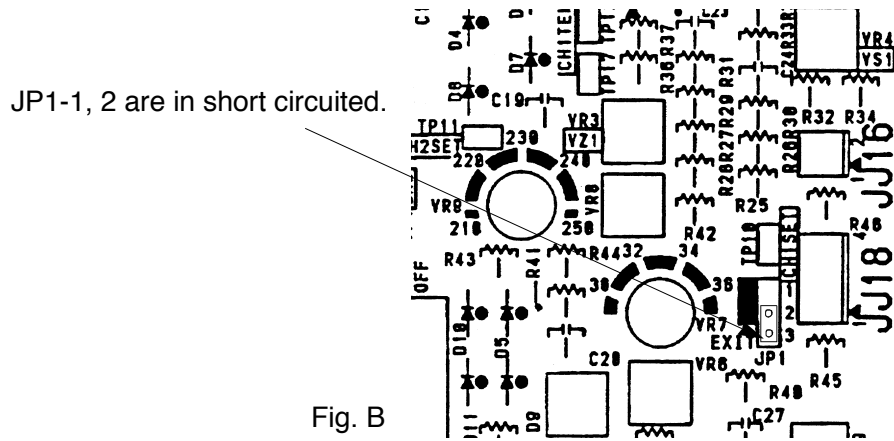

2) Start of SRX-101A

Turn on the power switch, set the DEV temp. control knob at 34°C, and turn on the RUN switch.

3) Actual temperature checking (Fig. F)

- ① Wait 5 minutes after READY lamp ON, then open the top cover.
- ② Measure the actual DEV temperature with a thermometer.
- ③ Further adjustment is not necessary if the temperature is between 33°C and 35°C.

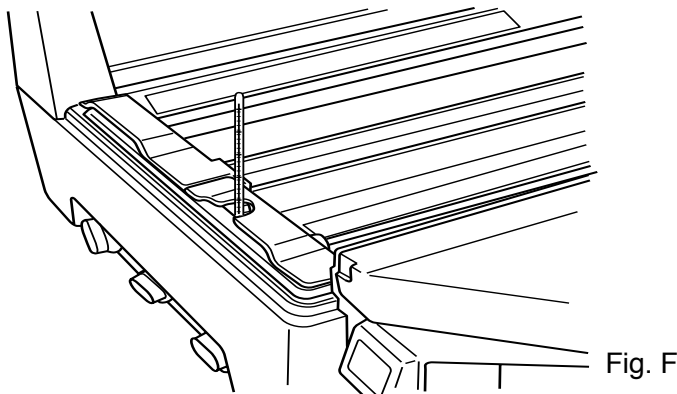

4)When the actual temperature is not between 33°C and 35°C, proceed the Knob position adjustment (Fig. G).

- ① Loosen the set screw of the knob which locates just opposite of the pointer.
Pay attention not to move the volume shaft.
- ② Set the pointer at the measured temperature value.
- ③ Tighten the set screw of the knob with the volume shaft not moving.

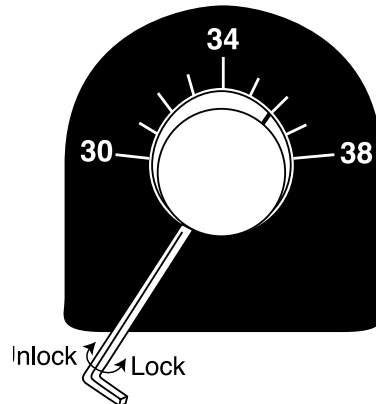

Fig. G

Next, make the adjustment according to the temperature conditions as Case 1 and Case 2.

Case 1 : When the actual temperature is over 35°C.

1)Cooling down of the DEV solution

Turn off RUN switch to wait the actual temperature becomes lower than 34°C

In order to check the temperature, make DEV solution circulating.

(Turn off the RUN switch immediately after turning it on, the DEV solution circulates 2 minutes.)

2)Recheck

After turn off the RUN switch, set the dial at 34°C, and turn on the RUN switch again.

Return to the step 3) Actual temperature checking.

Case 2 : When the actual temperature is under 33°C.

Make the above step 2) Recheck.

Konica

1051-55030A
1052

KONICA MEDICAL CORP.

411 Newark Pompton Turnpike, Wayne, NJ 07470, U.S.A.
TEL.973-633-1500

KONICA FRANCE S.A.

Paris Nord II, 305 rue de la Belle Etoile, B.P. 50077, 95948
ROISSY C.D.G. CEDEX, FRANCE
TEL.1-4938-6550

KONICA CANADA INC.

1329 Meyerside Drive, Mississauga, Ontario
L5T 1C9, CANADA
TEL.905-670-7722

KONICA U.K. LTD.

Plane Tree Crescent, Feltham, Middlesex
TW13 7HD, U.K.
TEL.1-81-751-6121

KONICA EUROPE GMBH

Friedrich-Bergius-Str. Gewerbegebiet,
85662 Hohenbrunn, GERMANY
TEL.8102-8040

KONICA AUSTRALIA PTY.LTD.

22 Giffnock Avenue, North Ryde, N.S.W. 2113, Australia
TEL.2-886-0333